

CL74LVC1G17 Single Schmitt-Trigger Buffer

General Description

The bus buffer gate is designed for 1.65-V to 5.5-V VCC operation.

The CL74LVC1G17 device contains one buffer and performs the Boolean function $Y = A$.

The CMOS device has high output drive while maintaining low static power dissipation over a broad VCC operating range.

The CL74LVC1G17 device is available in a variety of packages, including the ultra-small DFN body size of 1 mm × 1 mm.

Ordering Information

Part Number	Package	
CL74LVC1G17	SOT-23-5	
	SOT-25	
	SOT-353	
	SOT-553	
	DFN1X1-4L	

Features

- Available in the Ultra Small DFN1X1
- Inputs Accept Voltages 1.65V to 5.5 V
- Max Tpd of 4.6 ns at 3.3 V
- Low Power Consumption, 10-μA Max ICC
- ±24-mA Output Drive at 3.3 V
- Latch-Up Performance Exceeds 100 mA Per JESD 78, Class II
- ESD Protection Exceeds JESD 22
 - 2000-V Human-Body Model (A114-A)
 - 1000-V Charged-Device Model (C101)

Applications

- AV Receiver
- Audio Dock: Portable
- Blu-ray Player and Home Theater
- Embedded PC
- MP3 Player/Recorder (Portable Audio)
- Personal Digital Assistant (PDA)
- Power: Telecom/Server AC/DC Supply: Single
- Controller: Analog and Digital
- Solid State Drive (SSD): Client and Enterprise
- TV: LCD/Digital and High-Definition (HDTV)
- Tablet: Enterprise
- Video Analytics: Server
- Wireless Headset, Keyboard, and Mouse

Pin Configuration

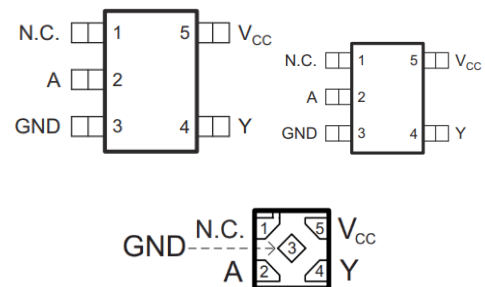

Simplified Schematic



Pin Name	Pin No.	Pin Function
NC	1	No Connect
A	2	Input
GND	3	Ground
Y	4	Output
VCC	5	Power pin

Absolute Maximum Ratings (Note1)

- V_{CC} ----- -0.5V to +6.5V
- V_I ----- -0.5V to +6.5V
- V_O (Voltage range applied to any output in the high-impedance or power-off state)----- -0.5V to +6.5V
- V_O (Voltage range applied to any output in the high or slow state)----- -0.5V to $V_{CC}+0.5V$
- Input clamp current ----- -50mA
- Output clamp current ----- -50mA
- Continuous output current ----- $\pm 50mA$
- Storage Temperature ----- $-65^{\circ}C$ to $150^{\circ}C$

Recommended Operating Conditions

Parameter	Symbol	Test Conditions	Min	Typ	Max	Units
Supply voltage	V_{CC}	Operating	1.65		5.5	V
		Data retention only	1.5			
Input voltage	V_I		0		5.5	V
Output voltage	V_O				VCC	V
High- level output current	I_{OH}	$V_{CC} = 1.65V$			-4	mA
		$V_{CC} = 2.3V$			-8	
		$V_{CC} = 3V$			-16	
		$V_{CC} = 3V$			-24	
		$V_{CC} = 4.5V$			-32	
Low- level output current	I_{OL}	$V_{CC} = 1.65V$			4	mA
		$V_{CC} = 2.3V$			8	
		$V_{CC} = 3V$			16	
		$V_{CC} = 3V$			24	
		$V_{CC} = 4.5V$			32	
Operating temperature	T_A		-40		125	$^{\circ}C$

Electrical Characteristics

Parameter	Symbol	Test Conditions	Min	Typ	Max	Units
Positive-going input threshold voltage	V_{T+}	$V_{CC} = 1.65V$	0.76		1.13	V
		$V_{CC} = 2.3V$	1.08		1.56	
		$V_{CC} = 3V$	1.48		1.92	
		$V_{CC} = 4.5V$	2.19		2.74	
		$V_{CC} = 5.5V$	2.65		3.33	
Negative-going input threshold voltage	V_{T-}	$V_{CC} = 1.65V$	0.35		0.59	V
		$V_{CC} = 2.3V$	0.56		0.88	
		$V_{CC} = 3V$	0.89		1.2	
		$V_{CC} = 4.5V$	1.51		1.97	
		$V_{CC} = 5.5V$	1.88		2.4	
Hysteresis voltage	ΔV_T	$V_{CC} = 1.65V$	0.36		0.64	V
		$V_{CC} = 2.3V$	0.45		0.78	
		$V_{CC} = 3V$	0.51		0.83	
		$V_{CC} = 4.5V$	0.58		0.93	
		$V_{CC} = 5.5V$	0.69		1.04	
High- level output voltage	V_{OH}	$V_{CC} = 1.65\sim 5.5V, I_{OH} = 100\mu A$	$V_{CC}-0.1$			V
		$V_{CC} = 1.65V, I_{OH} = 4mA$	1.2			
		$V_{CC} = 2.3V, I_{OH} = 8mA$	1.9			
		$V_{CC} = 3V, I_{OH} = 16mA$	2.4			
		$V_{CC} = 3V, I_{OH} = 24mA$	2.3			
		$V_{CC} = 4.5V, I_{OH} = 32mA$	3.8			
Low- level output voltage	V_{OL}	$V_{CC} = 1.65\sim 5.5V, I_{OL} = 100\mu A$			0.1	V
		$V_{CC} = 1.65V, I_{OL} = 4mA$			0.45	
		$V_{CC} = 2.3V, I_{OL} = 8mA$			0.3	
		$V_{CC} = 3V, I_{OL} = 16mA$			0.4	
		$V_{CC} = 3V, I_{OL} = 24mA$			0.55	
		$V_{CC} = 4.5V, I_{OL} = 32mA$			0.55	
Input leakage current	I_I	$V_{IN} = 5.5V$ or GND, $V_{CC} = 0\sim 5.5V$			± 5	μA
Power off leakage current	I_{OFF}	V_I or $V_O = 5.5V, V_{CC} = 0V$			± 10	μA
Supply current	I_{CC}	$V_{IN} = V_{CC}$ or GND, $I_{OUT} = 0, V_{CC} = 1.65\sim 5.5V$			10	μA
Additional supply current per input pin	ΔI_{CC}	$V_{CC} = 3\sim 5.5V$, one input at $V_{CC}-0.6V$, other input at V_{CC} or GND			500	μA

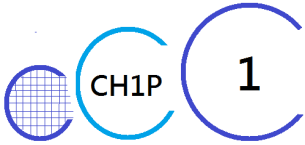

CL74LVC1G17

Switching Characteristics

Parameter	Symbol	Test Conditions	Min	Typ	Max	Units
Propagation delay from input(A or B) to output(Y)	T_{PD}	$V_{CC} = 1.8V \pm 0.15V,$	2.8		9.9	ns
		$V_{CC} = 2.5V \pm 0.2V$	1.6		5.5	
		$V_{CC} = 3.3V \pm 0.3V$	1.5		4.6	
		$V_{CC} = 5V \pm 0.5V$	0.9		4.4	

Parameter Measurement Information

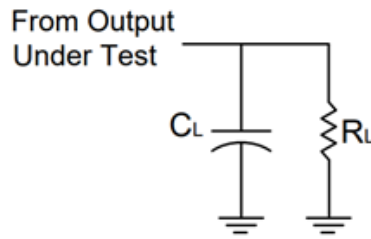

VCC	INPUTS		V _M	C _L	R _L
	V _I	t _r /t _f			
1.8V ± 0.15V	V _{CC}	≤ 2ns	V _{CC} /2	15pF	1MΩ
2.5V ± 0.2V	V _{CC}	≤ 2ns	V _{CC} /2	15pF	1MΩ
3.3V ± 0.3V	3V	≤ 2.5ns	1.5V	15pF	1MΩ
5V ± 0.5V	V _{CC}	≤ 2.5ns	V _{CC} /2	15pF	1MΩ

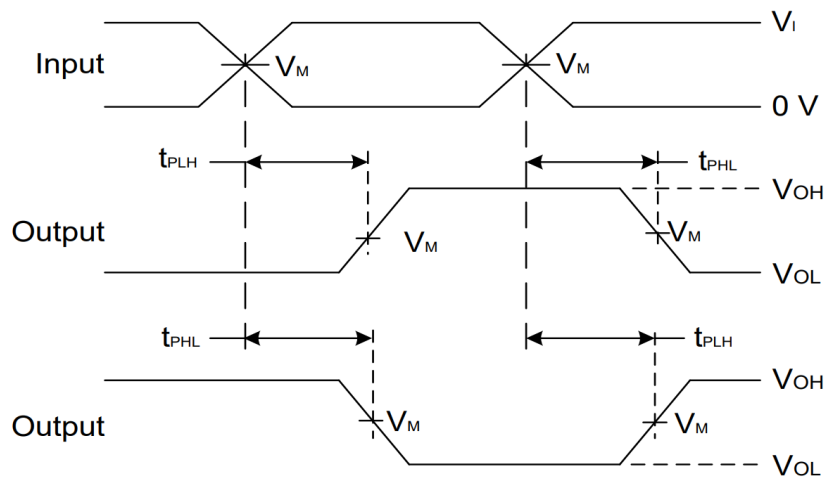

**Voltage Waveform Propagation Delay Times
Inverting and Non Inverting Outputs**

- Notes:
- A. C_L includes probe and jig capacitance
 - B. All pulses and supplied at pulse repetition rate ≤ 10MHz
 - C. The Inputs are measured separately one transition per measurement
 - D. t_{PLH} and t_{PHL} are the same as t_{PD}

PAD Location and Coordinates

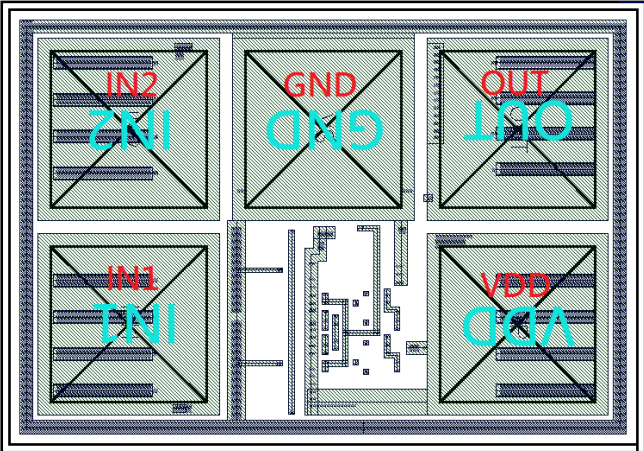
PHYSICAL CHARACTERISTICS		UNIT	CHIP DRAWING
Wafer Size	200	mm	
Die Size (with S/L)	0.308 * 0.233	mm ²	
Scribe line width	60	um	
TOP Metal thickness	3	um	
Top Metallization	Al-Cu		
Wafer Thickness	726	um	
CUP (circuit under PAD) or not	YES		
Bonding Wire Diameter	20	um	

PAD NAME	PAD SIZE (μm ²)	Coordinate
IN 1	60*60	(49,49)
IN 2	60*60	(49,124)
GND	60*60	(124,124)
OUT (Y)	60*60	(199,124)
VDD	60*60	(199,49)

Bonding Diagram Example

