

## CL74LVC1G07 Single Buffer/Driver With Open-Drain Output

### General Description

This single buffer/driver is designed for 1.65-V to 5.5-V VCC operation.

The output of the CL74LVC1G07 device is open drain and can be connected to other open-drain outputs to implement active-low wired-OR or active-high wired-AND functions. The maximum sink current is 32 mA.

The CL74LVC1G07 is available in a variety of packages, including the ultra-small DFN package with a body size of 1 mm × 1 mm.

### Ordering Information

Part Number	Package	
CL74LVC1G07	SOT-23-5	
	SOT-25	
	SOT-353	
	SOT-553	
	DFN1X1-4L	

### Features

- Available in the Ultra Small DFN1X1
- Inputs Accept Voltages 1.65V to 5.5 V
- Max Tpd of 4.2 ns at 3.3 V
- Low Power Consumption, 10-μA Max I<sub>CC</sub>
- ±24-mA Output Drive at 3.3 V
- Latch-Up Performance Exceeds 100 mA Per JESD 78, Class II
- ESD Protection Exceeds JESD 22
  - 2000-V Human-Body Model (A114-A)
  - 1000-V Charged-Device Model (C101)

### Applications

- AV Receiver
- Blu-ray Player and Home Theater
- DVD Recorders and Players

- Desktop or Notebook PCs
- Digital Radio or Internet Radio Players
- Digital Video Cameras (DVC)
- Embedded PC
- GPS: Personal Navigation Devices
- Mobile Internet Devices
- Network Projector Front-Ends
- Portable Media Players
- Pro Audio Mixers
- Smoke Detectors
- Solid State Drive (SSD): Enterprise
- High-Definition (HDTV)
- Tablet: Enterprise
- Audio Dock: Portable
- DLP Front Projection Systems
- DVR and DVS
- Digital Picture Frame (DPF)
- Digital Still Cameras

### Pin Configuration

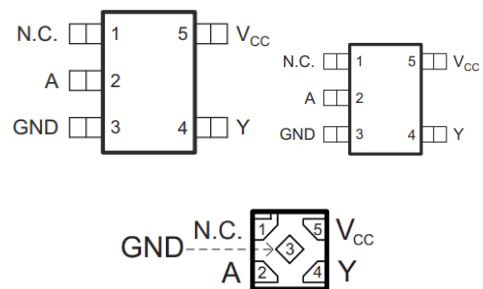

### Simplified Schematic



## Pin Assignment

Pin Name	Pin No.	Pin Function
NC	1	No Connect
A	2	Input
GND	3	Ground
Y	4	Output
VCC	5	Power pin

## Absolute Maximum Ratings (Note1)

- $V_{CC}$  ----- -0.5V to +6.5V
- $V_I$ ----- -0.5V to +6.5V
- $V_O$ (Voltage range applied to any output in the high-impedance or power-off state)----- -0.5V to +6.5V
- $V_O$ (Voltage range applied to any output in the high or slow state)----- -0.5V to  $V_{CC}+0.5V$
- Input clamp current ----- -50mA
- Output clamp current ----- -50mA
- Continuous output current -----  $\pm 50mA$
- Storage Temperature -----  $-65^{\circ}C$  to  $150^{\circ}C$

## Recommended Operating Conditions

Parameter	Symbol	Test Conditions	Min	Typ	Max	Units
Supply voltage	$V_{CC}$	Operating	1.65		5.5	V
		Data retention only	1.5			
Input voltage	$V_I$		0		5.5	V
Output voltage	$V_O$				$V_{CC}$	V
High- level input voltage	$V_{IH}$	$V_{CC} = 1.65V$ to $1.95V$	$0.65 \times V_{CC}$			V
		$V_{CC} = 2.3V$ to $2.7V$	1.7			
		$V_{CC} = 3V$ to $3.6V$	2			
		$V_{CC} = 4.5V$ to $5.5V$	$0.7 \times V_{CC}$			
Low- level input voltage	$V_{IL}$	$V_{CC} = 1.65V$ to $1.95V$			$0.35 \times V_{CC}$	V
		$V_{CC} = 2.3V$ to $2.7V$			0.7	
		$V_{CC} = 3V$ to $3.6V$			0.8	
		$V_{CC} = 4.5V$ to $5.5V$			$0.3 \times V_{CC}$	

Low- level output current	$I_{OL}$	$V_{CC} = 1.65V$			4	mA
		$V_{CC} = 2.3V$			8	
		$V_{CC} = 3V$			16	
		$V_{CC} = 3V$			24	
		$V_{CC} = 4.5V$			32	
Input transition rise or fall rate	$\Delta T/\Delta V$	$V_{CC} = 1.8V\pm 0.15V, 2.5V\pm 0.2V$			20	ns/V
		$V_{CC} = 3.3V\pm 0.3V$			10	
		$V_{CC} = 5V\pm 0.5V$			5	
Operating temperature	$T_A$		-40		125	$^{\circ}C$

## Electrical Characteristics

Parameter	Symbol	Test Conditions	Min	Typ	Max	Units
Low- level output voltage	$V_{OL}$	$V_{CC} = 1.65\sim 5.5V, I_{OL} = 100\mu A$			0.1	V
		$V_{CC} = 1.65V, I_{OL} = 4mA$			0.45	
		$V_{CC} = 2.3V, I_{OL} = 8mA$			0.3	
		$V_{CC} = 3V, I_{OL} = 16mA$			0.4	
		$V_{CC} = 3V, I_{OL} = 24mA$			0.55	
		$V_{CC} = 4.5V, I_{OL} = 32mA$			0.55	
Input leakage current	$I_I$	$V_{IN} = 5.5V$ or GND, $V_{CC} = 0\sim 5.5V$			$\pm 5$	$\mu A$
Power off leakage current	$I_{OFF}$	$V_I$ or $V_O = 5.5V, V_{CC} = 0V$			$\pm 10$	$\mu A$
Supply current	$I_{CC}$	$V_{IN} = V_{CC}$ or GND, $I_{OUT} = 0, V_{CC} = 1.65\sim 5.5V$			10	$\mu A$
Additional supply current per input pin	$\Delta I_{CC}$	$V_{CC} = 3\sim 5.5V$ , one input at $V_{CC} - 0.6V$ , other input at $V_{CC}$ or GND			500	$\mu A$

## Switching Characteristics

Parameter	Symbol	Test Conditions	Min	Typ	Max	Units
Propagation delay from input(A or B) to output(Y)	$T_{PD}$	$V_{CC} = 1.8V\pm 0.15V, R_L = 1K\Omega$	2.4		8.3	ns
		$V_{CC} = 2.5V\pm 0.2V, R_L = 500\Omega$				
		$V_{CC} = 3.3V\pm 0.3V, R_L = 500\Omega$	1.5		4.2	
		$V_{CC} = 5V\pm 0.5V, R_L = 500\Omega$				

## Parameter Measurement Information

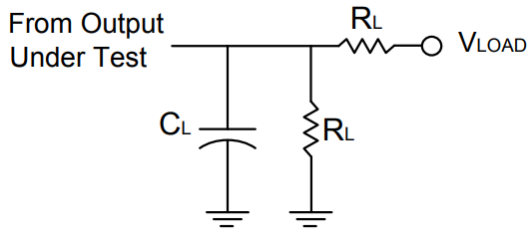

TEST	Condition
$t_{PLZ}$	$V_{LOAD}$
$t_{PZL}$	$V_{LOAD}$

VCC	INPUTS		$V_M$	$V_{LOAD}$	$C_L$	$R_L$	$V_{\Delta}$
	$V_I$	$t_r/t_f$					
$1.8V \pm 0.15V$	$V_{CC}$	$\leq 2ns$	$V_{CC}/2$	$2 \times V_{CC}$	30pF	1k $\Omega$	0.15V
$2.5V \pm 0.2V$	$V_{CC}$	$\leq 2ns$	$V_{CC}/2$	$2 \times V_{CC}$	30pF	500 $\Omega$	0.15V
$3.3V \pm 0.3V$	3V	$\leq 2.5ns$	1.5V	6V	50pF	500 $\Omega$	0.3V
$5V \pm 0.5V$	$V_{CC}$	$\leq 2.5ns$	$V_{CC}/2$	$2 \times V_{CC}$	50pF	500 $\Omega$	0.3V

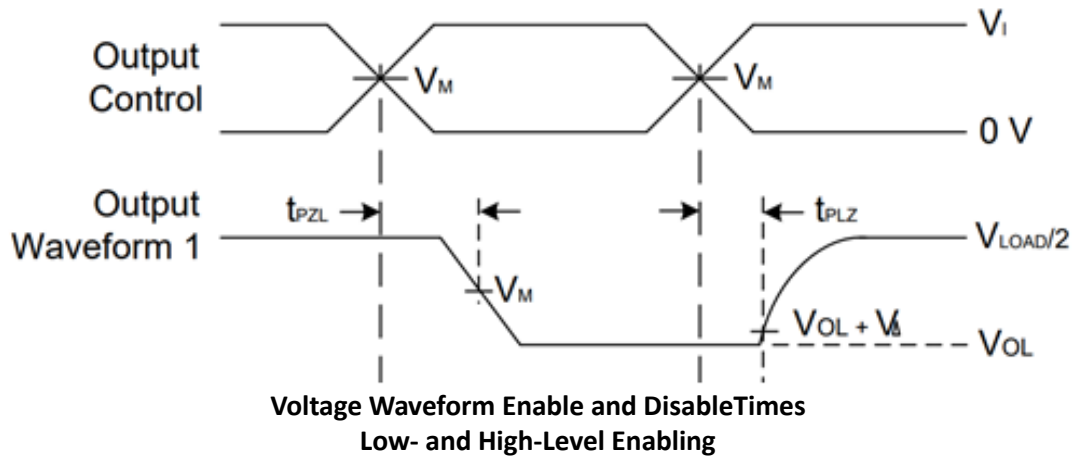

- Notes:
- A.  $C_L$  includes probe and jig capacitance
  - B. All pulses and supplied at pulse repetition rate  $\leq 10MHz$
  - C. The Inputs are measured one at a time with one transition per measurement
  - D. For the open drain device  $t_{PLZ}$  and  $t_{PZL}$  are the same as  $t_{PD}$
  - E.  $t_{PZL}$  is measured at  $V_M$
  - F.  $t_{PLZ}$  is measured at  $V_{OL} + V_{\Delta}$

## PAD Location and Coordinates

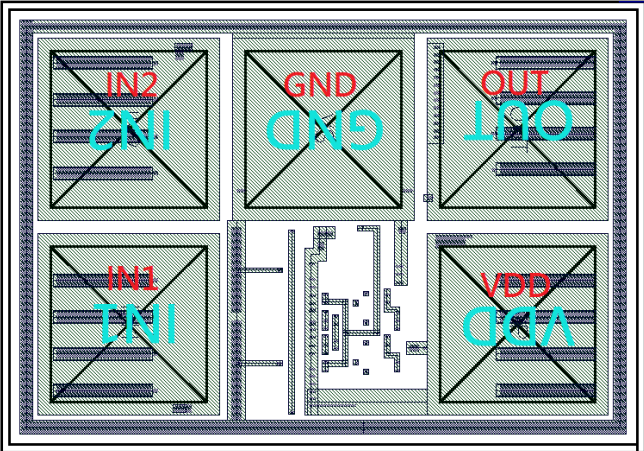
PHYSICAL CHARACTERISTICS		UNIT	CHIP DRAWING
Wafer Size	200	mm	
Die Size (with S/L)	0.308 * 0.233	mm <sup>2</sup>	
Scribe line width	60	um	
TOP Metal thickness	3	um	
Top Metallization	Al-Cu		
Wafer Thickness	726	um	
CUP (circuit under PAD) or not	YES		
Bonding Wire Diameter	20	um	

PAD NAME	PAD SIZE (μm <sup>2</sup> )	Coordinate
IN 1	60*60	(49,49)
IN 2	60*60	(49,124)
GND	60*60	(124,124)
OUT (Y)	60*60	(199,124)
VDD	60*60	(199,49)

Bonding Diagram Example

