

## CL74LV1T125 Single Power Supply Single Buffer Gate with 3-State Output CMOS Logic Level Shifter

### General Description

The SN74LV1T125 is a single buffer gate with reduced input thresholds to support voltage translation applications.

### Ordering Information

Part Number	Package	
CL74LV1T125	SOT-23-5 SOT-353	

### Features

- Single-supply voltage translator at 5.0V, 3.3V, 2.5V, and 1.8V V<sub>CC</sub>
- Operating range of 1.8V to 5.5V
- Up translation:
  - 1.2V to 1.8V at 1.8V V<sub>CC</sub>
  - 1.5V to 2.5V at 2.5V V<sub>CC</sub>
  - 1.8V to 3.3V at 3.3V V<sub>CC</sub>
  - 3.3V to 5.0V at 5.0V V<sub>CC</sub>
- Down translation:
  - 3.3V to 1.8V at 1.8V V<sub>CC</sub>
  - 3.3V to 2.5V at 2.5V V<sub>CC</sub>
  - 5.0V to 3.3V at 3.3V V<sub>CC</sub>

- Output drive:
  - 8mA output drive at 5V
  - 7mA output drive at 3.3V
  - 3mA output drive at 1.8V
- Characterized up to 50MHz at 3.3V V<sub>CC</sub>
- 5V tolerance on input pins
- –40°C to +125°C operating temperature range
- Supports standard logic pinouts

### Applications

- Telecom
- Portable applications
- Servers
- PC and notebooks

### Pin Configuration

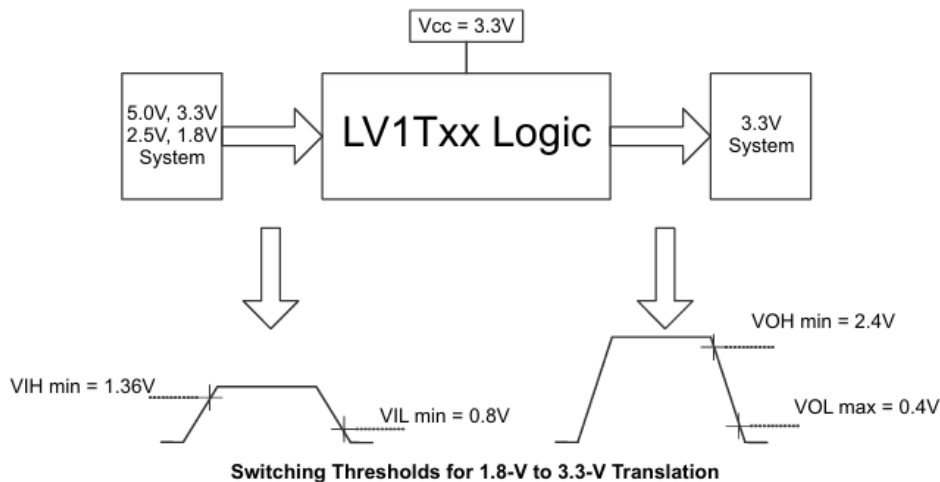
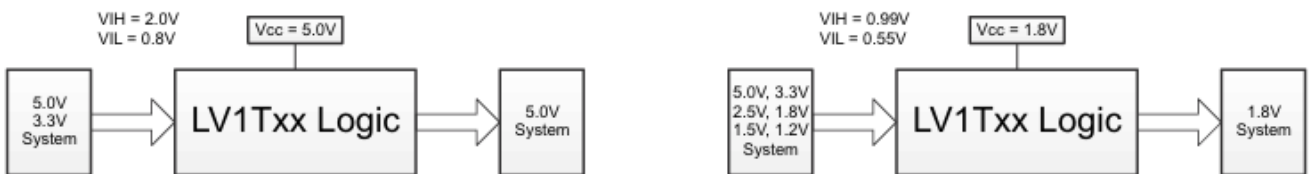
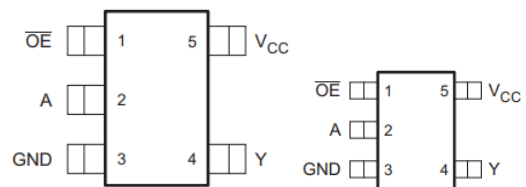



## Pin Assignment

# CL74LV1T125

Pin Name	Pin No.	Pin Function
$\overline{OE}$	1	Input
A	2	Input
GND	3	Ground
Y	4	Output
VCC	5	Power pin

## Absolute Maximum Ratings (Note1)

- $V_{CC}$  ----- -0.5V to +7.0V
- $V_I$ ----- -0.5V to +7.0V
- $V_O$ (Voltage range applied to any output in the high or slow state)----- -0.5V to  $V_{CC}+0.5V$
- Input clamp current ----- -20mA
- Output clamp current -----  $\pm 20mA$
- Continuous output current -----  $\pm 25mA$
- Storage Temperature -----  $-65^{\circ}C$  to  $150^{\circ}C$

## Recommended Operating Conditions

Parameter	Symbol	Test Conditions	Min	Typ	Max	Units
Supply voltage	$V_{CC}$	Operating	1.6		5.5	V
Input voltage	$V_I$		0		5.5	V
Output voltage	$V_O$		0		$V_{CC}$	V
High- level output current	$I_{OH}$	$V_{CC} = 1.8V$			-3	mA
		$V_{CC} = 2.5V$			-5	
		$V_{CC} = 3.3V$			-7	
		$V_{CC} = 5.0V$			-8	
Low- level output current	$I_{OL}$	$V_{CC} = 1.8V$			3	mA
		$V_{CC} = 2.5V$			5	
		$V_{CC} = 3.3V$			7	
		$V_{CC} = 5.0V$			8	
Input transition rise or fall rate	$\Delta T/\Delta V$	$V_{CC} = 1.8V$			20	ns/V
		$V_{CC} = 3.3V$ or $2.5V$			20	
		$V_{CC} = 5V$			20	
Operating temperature	$T_A$		-40		125	$^{\circ}C$

## Electrical Characteristics

Parameter	Symbol	Test Conditions	Min	Typ	Max	Units
High- level input voltage	$V_{IH}$	$V_{CC} = 1.65\sim 1.8V$	0.99			V
		$V_{CC} = 2.0V$	0.99			
		$V_{CC} = 2.25\sim 2.5V$	1.145			
		$V_{CC} = 2.75V$	1.22			
		$V_{CC} = 3\sim 3.3V$	1.37			
		$V_{CC} = 3.6V$	1.47			
		$V_{CC} = 4.5V\sim 5.0V$	2.02			
		$V_{CC} = 5.5V$	2.1			
Low- level input voltage	$V_{IL}$	$V_{CC} = 1.65\sim 2.0V$			0.57	V
		$V_{CC} = 2.25\sim 2.75V$			0.75	
		$V_{CC} = 3\sim 3.6V$			0.8	
		$V_{CC} = 4.5V\sim 5.5V$			0.8	
High- level output voltage	$V_{OH}$	$V_{CC} = 1.65\sim 5.5V, I_{OH} = -20\mu A$	$V_{CC}-0.1$			V
		$V_{CC} = 1.65V, I_{OH} = -2mA$	1.28			
		$V_{CC} = 1.8V, I_{OH} = -2mA$	1.5			
		$V_{CC} = 2.3V, I_{OH} = -3mA$	2.0			
		$V_{CC} = 2.5V, I_{OH} = -3mA$	2.25			
		$V_{CC} = 3.0V, I_{OH} = -3mA$	2.78			
		$V_{CC} = 3.0V, I_{OH} = -5.5mA$	2.6			
		$V_{CC} = 3.3V, I_{OH} = -5.5mA$	2.9			
		$V_{CC} = 4.5V, I_{OH} = -4mA$	4.2			
		$V_{CC} = 4.5V, I_{OH} = -8mA$	4.1			
		$V_{CC} = 5.0V, I_{OH} = -8mA$	4.6			
Low- level output voltage	$V_{OL}$	$V_{CC} = 1.65\sim 5.5V, I_{OL} = 20\mu A$			0.1	V
		$V_{CC} = 1.65V, I_{OL} = 2mA$			0.2	
		$V_{CC} = 2.3V, I_{OL} = 3mA$			0.15	
		$V_{CC} = 3V, I_{OL} = 3mA$			0.11	
		$V_{CC} = 3V, I_{OL} = 5.5mA$			0.21	
		$V_{CC} = 4.5V, I_{OL} = 4mA$			0.15	
		$V_{CC} = 4.5V, I_{OL} = 8mA$			0.3	
Input leakage current	$I_I$	$V_{IN} = V_{CC}$ or GND, $V_{CC} = 0\sim 5.5V$			0.1	$\mu A$
Supply current	$I_{CC}$	$V_{IN} = V_{CC}$ or GND, $I_{OUT} = 0, V_{CC} = 1.8\sim 5.0V$			1	$\mu A$
Additional supply current per input pin	$\Delta I_{CC}$	$V_{CC} = 5.5V$ , one input at 0.3V or 3.4V, other input at $V_{CC}$ or GND, $I_{OUT} = 0$			1.35	$\mu A$
		$V_{CC} = 1.8V$ , one input at 0.3V or 1.1V, other input at $V_{CC}$ or GND, $I_{OUT} = 0$			10	

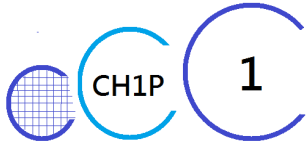

Switching Characteristics

Parameter	From Input	To Output	Test Conditions	Min	Typ	Max	Units
T <sub>PD</sub>	A	Y	V <sub>CC</sub> = 5.0V		2.7	5.5	ns
			V <sub>CC</sub> = 3.3V		4.0	7.0	
			V <sub>CC</sub> = 2.5V		5.8	8.5	
			V <sub>CC</sub> = 1.8V		10.5	13.0	
T <sub>en</sub>	$\overline{OE}$	Y	V <sub>CC</sub> = 5.0V		3.0	5.0	ns
			V <sub>CC</sub> = 3.3V		4.0	6.5	
			V <sub>CC</sub> = 2.5V		5.5	8.0	
			V <sub>CC</sub> = 1.8V		9.0	12.0	
T <sub>dis</sub>	$\overline{OE}$	Y	V <sub>CC</sub> = 5.0V		4.2	6.5	ns
			V <sub>CC</sub> = 3.3V		4.5	7.0	
			V <sub>CC</sub> = 2.5V		5.0	11.0	
			V <sub>CC</sub> = 1.8V		8.0	10.0	

## Parameter Measurement Information

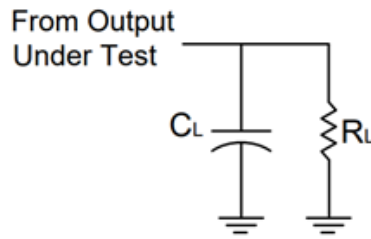

VCC	INPUTS		V <sub>M</sub>	C <sub>L</sub>	R <sub>L</sub>
	V <sub>I</sub>	t <sub>r</sub> /t <sub>f</sub>			
1.8V ± 0.15V	V <sub>CC</sub>	≤ 2ns	V <sub>CC</sub> /2	15pF	1MΩ
2.5V ± 0.2V	V <sub>CC</sub>	≤ 2ns	V <sub>CC</sub> /2	15pF	1MΩ
3.3V ± 0.3V	3V	≤ 2.5ns	1.5V	15pF	1MΩ
5V ± 0.5V	V <sub>CC</sub>	≤ 2.5ns	V <sub>CC</sub> /2	15pF	1MΩ

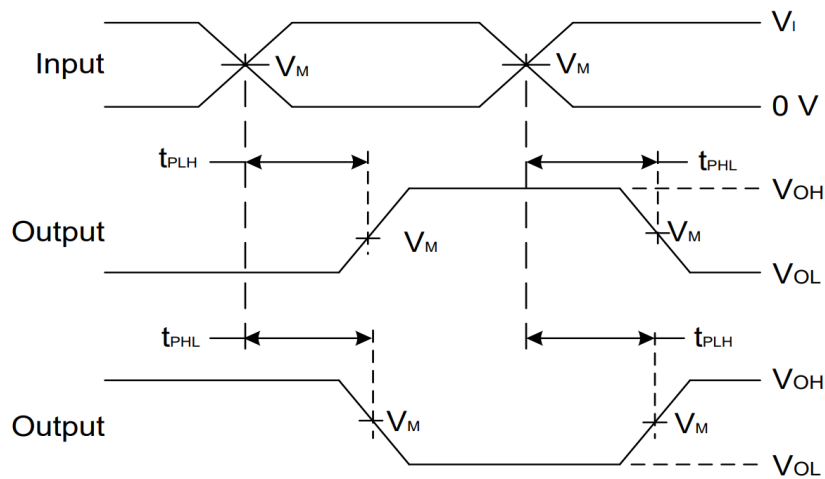

**Voltage Waveform Propagation Delay Times  
Inverting and Non Inverting Outputs**

- Notes:
- A. C<sub>L</sub> includes probe and jig capacitance
  - B. All pulses and supplied at pulse repetition rate ≤ 10MHz
  - C. t<sub>PLH</sub> and t<sub>PHL</sub> are the same as t<sub>PD</sub>

## PAD Location and Coordinates

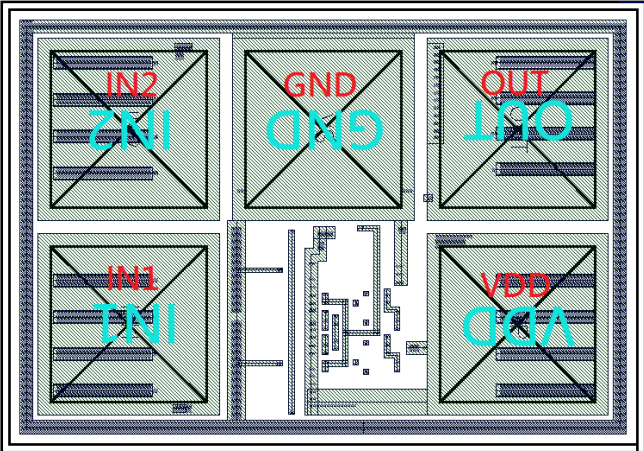
PHYSICAL CHARACTERISTICS		UNIT	CHIP DRAWING
Wafer Size	200	mm	
Die Size (with S/L)	0.308 * 0.233	mm <sup>2</sup>	
Scribe line width	60	um	
TOP Metal thickness	3	um	
Top Metallization	Al-Cu		
Wafer Thickness	726	um	
CUP (circuit under PAD) or not	YES		
Bonding Wire Diameter	20	um	

PAD NAME	PAD SIZE (μm <sup>2</sup> )	Coordinate
IN 1	60*60	(49,49)
IN 2	60*60	(49,124)
GND	60*60	(124,124)
OUT (Y)	60*60	(199,124)
VDD	60*60	(199,49)

Bonding Diagram Example

