

## CL74AUP1G86 Low- Power Single 2-Input Positive Exclusive-OR Gate

### General Description

This single 2-input exclusive-OR gate is designed for 0.8-V to 3.6-V VCC operation.

The CL74AUP1G86 performs the Boolean function  $Y = \bar{A}B + A\bar{B}$  in positive logic.

The CMOS device has high output drive while maintaining low static power dissipation over a broad VCC operating range.

The CL74AUP1G86 device is available in a variety of packages, including the ultra-small DFN body size of 1 mm × 1 mm.

### Ordering Information

Part Number	Package	
CL74AUP1G86	SOT-23-5	
	SOT-25	
	SOT-353	
	SOT-553	
	DFN1X1-4L	

### Features

- Available in the Ultra Small DFN1X1
- Inputs Accept Voltages 0.8V to 3.6 V
- Max Tpd of 5.4 ns at 3.3 V
- Low Static-Consumption, 0.9-µA Max ICC
- Low Noise Overshoot and Undershoot < 10% of VCC
- Ioff Supports Live Insertion, Partial-Power-Down Mode, and Back-Drive Protection
- Input Hysteresis Allows Slow Input Transition and Better Switching Noise Immunity at Input (V<sub>hys</sub> = 250mV Typical 3.3V)
- 3.6V I/O Tolerant to Support Mixed-Mode Signal Operation
- Suitable for Point-to-Point Applications
- Latch-Up Performance Exceeds 100 mA Per JESD 78, Class II
- ESD Protection Exceeds JESD 22

- 2000-V Human-Body Model (A114-A)
- 1000-V Charged-Device Model (C101)

### Applications

- ATCA Solutions
- Active Noise Cancellation (ANC)
- Barcode Scanner
- Blood Pressure Monitor
- CPAP Machine
- Cable Solutions
- DLP 3DMachine Vision, Hyperspectral Imaging, Optical Networking, and Spectroscopy
- E-Book
- Embedded PC
- Field Transmitter: Temperature or Pressure Sensor
- Fingerprint Biometrics
- HVAC: Heating, Ventilating, and Air Conditioning

### Pin Configuration

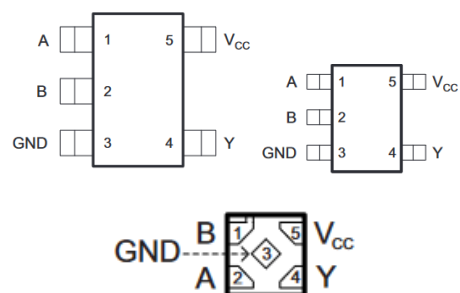

### Simplified Schematic





## Pin Assignment

# CL74AUP1G86

Pin Name	Pin No.	Pin Function
A	1	Input
B	2	Input
GND	3	Ground
Y	4	Output
VCC	5	Power pin

### Absolute Maximum Ratings (Note1)

- $V_{CC}$  ----- -0.5V to +4.6V
- $V_I$ ----- -0.5V to +4.6V
- $V_O$ (Voltage range applied to any output in the high-impedance or power-off state)----- -0.3V to +4.6V
- $V_O$ (Voltage range applied to any output in the high or slow state)----- -0.3V to  $V_{CC}+0.3V$
- Input clamp current ----- -50mA
- Output clamp current ----- -50mA
- Continuous output current -----  $\pm 20mA$
- Storage Temperature -----  $-65^{\circ}C$  to  $150^{\circ}C$

### Recommended Operating Conditions

Parameter	Symbol	Test Conditions	Min	Typ	Max	Units
Supply voltage	$V_{CC}$	Operating	0.8		3.6	V
Input voltage	$V_I$		0		3.6	V
Output voltage	$V_O$		0		$V_{CC}$	V
High- level input voltage	$V_{IH}$	$V_{CC} = 0.8V$	$V_{CC}$			V
		$V_{CC} = 1.1V$ to $1.95V$	$0.65 \times V_{CC}$			
		$V_{CC} = 2.3V$ to $2.7V$	1.6			
		$V_{CC} = 3V$ to $3.6V$	2			
Low- level input voltage	$V_{IL}$	$V_{CC} = 0.8V$			0	V
		$V_{CC} = 1.1V$ to $1.95V$			$0.35 \times V_{CC}$	
		$V_{CC} = 2.3V$ to $2.7V$			0.7	
		$V_{CC} = 3V$ to $3.6V$			0.9	

High- level output current	$I_{OH}$	$V_{CC} = 0.8V$			-20	uA
		$V_{CC} = 1.1V$			-1.1	mA
		$V_{CC} = 1.4V$			-1.7	
		$V_{CC} = 1.65V$			-1.9	
		$V_{CC} = 2.3V$			-3.1	
		$V_{CC} = 3V$			-4	
Low- level output current	$I_{OL}$	$V_{CC} = 0.8V$			20	uA
		$V_{CC} = 1.1V$			1.1	mA
		$V_{CC} = 1.4V$			1.7	
		$V_{CC} = 1.65V$			1.9	
		$V_{CC} = 2.3V$			3.1	
		$V_{CC} = 3V$			4	
Input transition rise or fall rate	$\Delta T/\Delta V$	$V_{CC} = 0.8V$ to $3.6V$			200	ns/V
Operating temperature	$T_A$		-40		85	°C

## Electrical Characteristics

Parameter	Symbol	Test Conditions	Min	Typ	Max	Units
High- level output voltage	$V_{OH}$	$V_{CC} = 0.8\sim 3.6V, I_{OH} = -20\mu A$	$V_{CC}-0.1$			V
		$V_{CC} = 1.1V, I_{OH} = -1.1mA$	$0.75 \times V_{CC}$			
		$V_{CC} = 1.4V, I_{OH} = -1.7mA$	1.11			
		$V_{CC} = 1.65V, I_{OH} = -1.9mA$	1.32			
		$V_{CC} = 2.3V, I_{OH} = -2.3mA$	2.05			
		$V_{CC} = 2.3V, I_{OH} = -3.1mA$	1.9			
		$V_{CC} = 3V, I_{OH} = -2.7mA$	2.72			
		$V_{CC} = 3V, I_{OH} = -4mA$	2.6			
Low- level output voltage	$V_{OL}$	$V_{CC} = 0.8\sim 3.6V, I_{OL} = 20\mu A$			0.1	V
		$V_{CC} = 1.1V, I_{OL} = 1.1mA$			$0.3 \times V_{CC}$	
		$V_{CC} = 1.4V, I_{OL} = 1.7mA$			0.31	
		$V_{CC} = 1.65V, I_{OL} = 1.9mA$			0.31	
		$V_{CC} = 2.3V, I_{OL} = 2.3mA$			0.31	
		$V_{CC} = 2.3V, I_{OL} = 3.1mA$			0.44	
		$V_{CC} = 3V, I_{OL} = 2.7mA$			0.31	
		$V_{CC} = 3V, I_{OL} = 4mA$			0.44	
Input leakage current	$I_I$	$V_{IN} = 3.6V$ or GND, $V_{CC} = 0\sim 3.6V$			0.1	uA
Power off leakage current	$I_{OFF}$	$V_I$ or $V_O = 0V$ to $3.6V, V_{CC} = 0V$			0.2	uA
Supply current	$I_{CC}$	$V_I = GND$ or ( $V_{CC}$ to $3.6V$ ), $I_{OUT} = 0$ , $V_{CC} = 0.8\sim 3.6V$			0.5	uA
Additional supply current per input pin	$\Delta I_{CC}$	$V_I = V_{CC} - 0.6V, I_{OUT} = 0$			40	uA

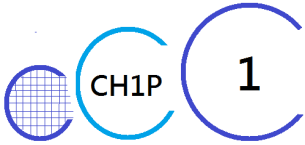

# CL74AUP1G86

## Switching Characteristics

Parameter	Symbol	Test Conditions	Min	Typ	Max	Units	
Propagation delay from input(A or B) to output(Y)	T <sub>PD</sub>	V <sub>CC</sub> = 0.8V		28.2		ns	
		V <sub>CC</sub> = 1.2V±0.1V,	C <sub>L</sub> =15pF R <sub>L</sub> =1MΩ	3.0	7.6		16.5
		V <sub>CC</sub> = 1.5V±0.1V,		2.4	5.3		9.6
		V <sub>CC</sub> = 1.8V±0.15V		2.1	4.4		7.5
		V <sub>CC</sub> = 2.5V±0.2V		1.8	3.6		5.9
		V <sub>CC</sub> = 3.3V±0.3V		1.6	3.3		5.4

## Parameter Measurement Information

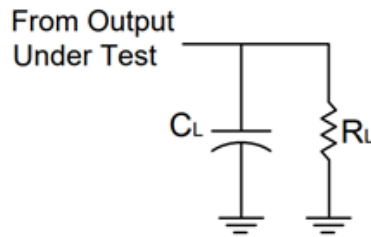

VCC	INPUTS		V <sub>M</sub>	C <sub>L</sub>	R <sub>L</sub>
	V <sub>I</sub>	t <sub>r</sub> /t <sub>f</sub>			
0.8V	V <sub>CC</sub>	≤ 2ns	V <sub>CC</sub> /2	15pF	1MΩ
1.2V ± 0.1V	V <sub>CC</sub>	≤ 2ns	V <sub>CC</sub> /2	15pF	1MΩ
1.5V ± 0.1V	V <sub>CC</sub>	≤ 2ns	V <sub>CC</sub> /2	15pF	1MΩ
1.8V ± 0.15V	V <sub>CC</sub>	≤ 2ns	V <sub>CC</sub> /2	15pF	1MΩ
2.5V ± 0.2V	3V	≤ 2.5ns	1.5V	15pF	1MΩ
3.3V ± 0.3V	V <sub>CC</sub>	≤ 2.5ns	V <sub>CC</sub> /2	15pF	1MΩ

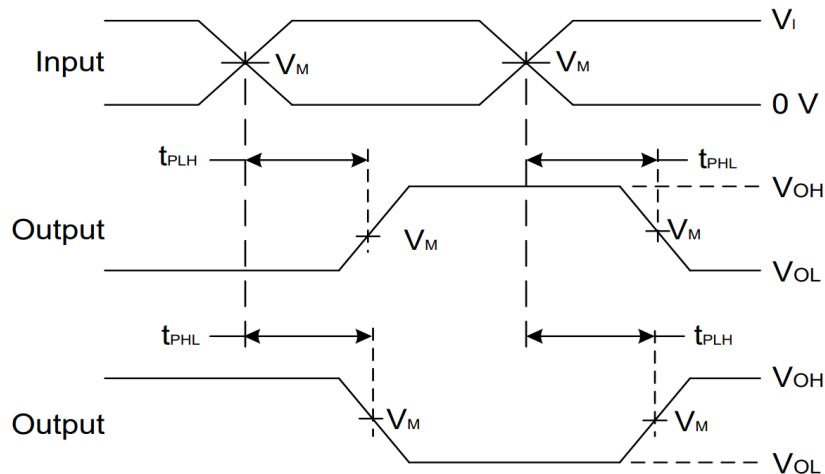

**Voltage Waveform Propagation Delay Times  
Inverting and Non Inverting Outputs**

- Notes:
- A. C<sub>L</sub> includes probe and jig capacitance
  - B. All pulses and supplied at pulse repetition rate ≤ 10MHz
  - C. The Inputs are measured separately one transition per measurement
  - D. t<sub>PLH</sub> and t<sub>PHL</sub> are the same as t<sub>PD</sub>

## PAD Location and Coordinates

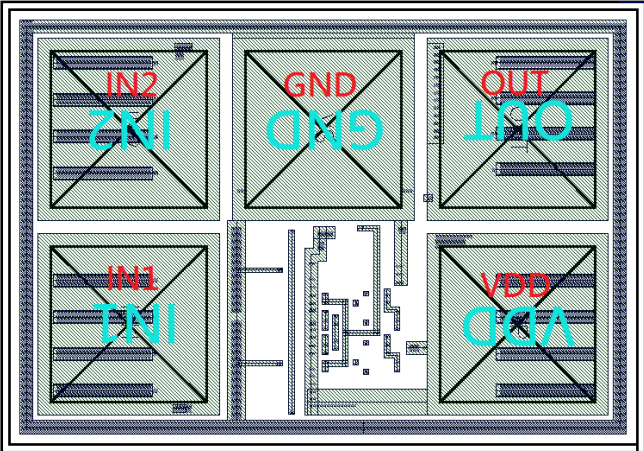
PHYSICAL CHARACTERISTICS		UNIT	CHIP DRAWING
Wafer Size	200	mm	
Die Size (with S/L)	0.308 * 0.233	mm <sup>2</sup>	
Scribe line width	60	um	
TOP Metal thickness	3	um	
Top Metallization	Al-Cu		
Wafer Thickness	726	um	
CUP (circuit under PAD) or not	YES		
Bonding Wire Diameter	20	um	

PAD NAME	PAD SIZE (μm <sup>2</sup> )	Coordinate
IN 1	60*60	(49,49)
IN 2	60*60	(49,124)
GND	60*60	(124,124)
OUT (Y)	60*60	(199,124)
VDD	60*60	(199,49)

Bonding Diagram Example

