

CL74AUP1G04 Low Power Single Inverter Gate

General Description

This single inverter gate is designed for 0.8-V to 3.6-V V_{CC} operation.

The CL74AUP1G04 device performs the Boolean function $Y = \overline{A}$.

The CMOS device has high output drive while maintaining low static power dissipation over a broad V_{CC} operating range.

The CL74AUP1G04 device is available in a variety of packages, including the ultra-small DFN body size of 1 mm × 1 mm.

Ordering Information

Part Number	Package	
CL74AUP1G04	SOT-23-5	
	SOT-25	
	SOT-353	
	SOT-553	
	DFN1X1-4L	

Features

- Available in the Ultra Small DFN1X1
- Inputs Accept Voltages 0.8V to 3.6 V
- Max Tpd of 5.4 ns at 3.3 V
- Low Static-Consumption, 0.9- μ A Max I_{CC}
- Low Noise Overshoot and Undershoot <10% of V_{CC}
- Ioff Supports Live Insertion, Partial-Power-Down Mode, and Back-Drive Protection
- Input Hysteresis Allows Slow Input Transition and Better Switching Noise Immunity at Input ($V_{hys} = 250\text{mV}$ Typical 3.3V)
- 3.6V I/O Tolerant to Support Mixed-Mode Signal Operation
- Suitable for Point-to-Point Applications
- Latch-Up Performance Exceeds 100 mA Per JESD 78, Class II

- ESD Protection Exceeds JESD 22
 - 2000-V Human-Body Model (A114-A)
 - 1000-V Charged-Device Model (C101)

Applications

- ATCA Solutions
- Active Noise Cancellation (ANC)
- Barcode Scanner
- Blood Pressure Monitor
- CPAP Machine
- Cable Solutions
- DLP 3DMachine Vision, Hyperspectral Imaging, Optical Networking, and Spectroscopy
- E-Book
- Embedded PC
- Field Transmitter: Temperature or Pressure Sensor
- Fingerprint Biometrics
- HVAC: Heating, Ventilating, and Air Conditioning

Pin Configuration

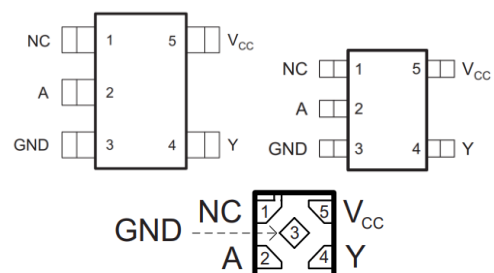

Simplified Schematic





Pin Assignment

Pin Name	Pin No.	Pin Function
NC	1	No connect
A	2	Input
GND	3	Ground
Y	4	Output
V _{CC}	5	Power pin

Absolute Maximum Ratings (Note1)

- V_{CC} ----- -0.5V to +4.6V
- V_I----- -0.5V to +4.6V
- V_O(Voltage range applied to any output in the high-impedance or power-off state)----- -0.3V to +4.6V
- V_O(Voltage range applied to any output in the high or slow state)----- -0.3V to V_{CC}+0.3V
- Input clamp current ----- -50mA
- Output clamp current ----- -50mA
- Continuous clamp current ----- ±20mA
- Storage Temperature ----- -65°C to 150°C

Recommended Operating Conditions

Parameter	Symbol	Test Conditions	Min	Typ	Max	Units
Supply voltage	V _{CC}	Operating	0.8		3.6	V
Input voltage	V _I		0		3.6	V
Output voltage	V _O		0		V _{CC}	V
High- level input voltage	V _{IH}	V _{CC} = 0.8V	V _{CC}			V
		V _{CC} = 1.1V to 1.95V	0.65 x V _{CC}			
		V _{CC} = 2.3V to 2.7V	1.6			
		V _{CC} = 3V to 3.6V	2			
Low- level input voltage	V _{IL}	V _{CC} = 0.8V			0	V
		V _{CC} = 1.1V to 1.95V			0.35 x V _{CC}	
		V _{CC} = 2.3V to 2.7V			0.7	
		V _{CC} = 3V to 3.6V			0.9	

High- level output current	I_{OH}	$V_{CC} = 0.8V$			-20	uA
		$V_{CC} = 1.1V$			-1.1	mA
		$V_{CC} = 1.4V$			-1.7	
		$V_{CC} = 1.65V$			-1.9	
		$V_{CC} = 2.3V$			-3.1	
		$V_{CC} = 3V$			-4	
Low- level output current	I_{OL}	$V_{CC} = 0.8V$			20	uA
		$V_{CC} = 1.1V$			1.1	mA
		$V_{CC} = 1.4V$			1.7	
		$V_{CC} = 1.65V$			1.9	
		$V_{CC} = 2.3V$			3.1	
		$V_{CC} = 3V$			4	
Input transition rise or fall rate	$\Delta T/\Delta V$	$V_{CC} = 0.8V$ to $3.6V$			200	ns/V
Operating temperature	T_A		-40		85	°C

Electrical Characteristics

Parameter	Symbol	Test Conditions	Min	Typ	Max	Units
High- level output voltage	V_{OH}	$V_{CC} = 0.8\sim 3.6V, I_{OH} = -20\mu A$	$V_{CC}-0.1$			V
		$V_{CC} = 1.1V, I_{OH} = -1.1mA$	$0.75 \times V_{CC}$			
		$V_{CC} = 1.4V, I_{OH} = -1.7mA$	1.11			
		$V_{CC} = 1.65V, I_{OH} = -1.9mA$	1.32			
		$V_{CC} = 2.3V, I_{OH} = -2.3mA$	2.05			
		$V_{CC} = 2.3V, I_{OH} = -3.1mA$	1.9			
		$V_{CC} = 3V, I_{OH} = -2.7mA$	2.72			
		$V_{CC} = 3V, I_{OH} = -4mA$	2.6			
Low- level output voltage	V_{OL}	$V_{CC} = 0.8\sim 3.6V, I_{OL} = 20\mu A$			0.1	V
		$V_{CC} = 1.1V, I_{OL} = 1.1mA$			$0.3 \times V_{CC}$	
		$V_{CC} = 1.4V, I_{OL} = 1.7mA$			0.31	
		$V_{CC} = 1.65V, I_{OL} = 1.9mA$			0.31	
		$V_{CC} = 2.3V, I_{OL} = 2.3mA$			0.31	
		$V_{CC} = 2.3V, I_{OL} = 3.1mA$			0.44	
		$V_{CC} = 3V, I_{OL} = 2.7mA$			0.31	
		$V_{CC} = 3V, I_{OL} = 4mA$			0.44	
Input leakage current	I_I	$V_{IN} = 3.6V$ or GND, $V_{CC} = 0\sim 3.6V$			0.1	uA
Power off leakage current	I_{OFF}	V_I or $V_O = 0V$ to $3.6V, V_{CC} = 0V$			0.2	uA
Supply current	I_{CC}	$V_I = GND$ or (V_{CC} to $3.6V$), $I_{OUT} = 0$, $V_{CC} = 0.8\sim 3.6V$			0.5	uA
Additional supply current per input pin	ΔI_{CC}	$V_I = V_{CC} - 0.6V, I_{OUT} = 0$			40	uA

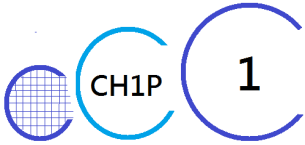

CL74AUP1G04

Switching Characteristics

Parameter	Symbol	Test Conditions	Min	Typ	Max	Units	
Propagation delay from input(A or B) to output(Y)	T _{PD}	V _{CC} = 0.8V		25.4		ns	
		V _{CC} = 1.2V±0.1V,	C _L =15pF R _L =1MΩ	6.8	10.4		16
		V _{CC} = 1.5V±0.1V,		5.3	7.6		10.8
		V _{CC} = 1.8V±0.15V		4.6	6.3		9.2
		V _{CC} = 2.5V±0.2V		3.6	4.8		6.5
		V _{CC} = 3.3V±0.3V		3.2	4		5.4

Parameter Measurement Information

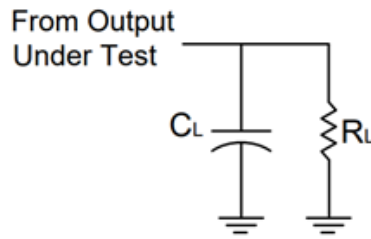

VCC	INPUTS		V _M	C _L	R _L
	V _I	t _r /t _f			
0.8V	V _{CC}	≤ 2ns	V _{CC} /2	15pF	1MΩ
1.2V ± 0.1V	V _{CC}	≤ 2ns	V _{CC} /2	15pF	1MΩ
1.5V ± 0.1V	V _{CC}	≤ 2ns	V _{CC} /2	15pF	1MΩ
1.8V ± 0.15V	V _{CC}	≤ 2ns	V _{CC} /2	15pF	1MΩ
2.5V ± 0.2V	3V	≤ 2.5ns	1.5V	15pF	1MΩ
3.3V ± 0.3V	V _{CC}	≤ 2.5ns	V _{CC} /2	15pF	1MΩ

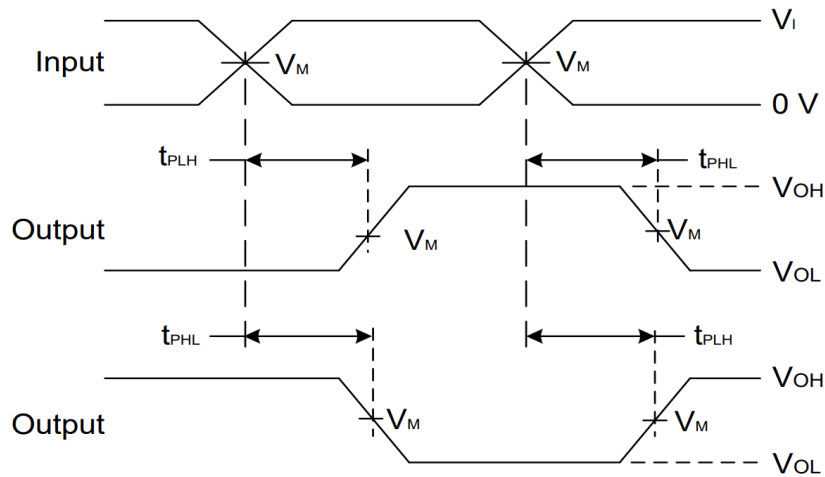

**Voltage Waveform Propagation Delay Times
Inverting and Non Inverting Outputs**

- Notes:
- A. C_L includes probe and jig capacitance
 - B. All pulses and supplied at pulse repetition rate ≤ 10MHz
 - C. t_{PLH} and t_{PHL} are the same as t_{PD}

PAD Location and Coordinates

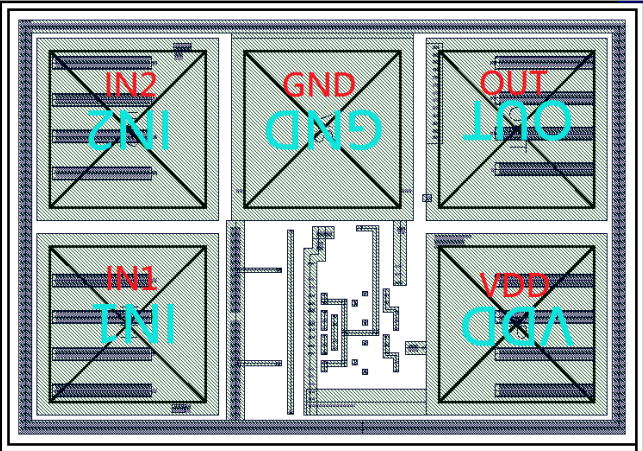
PHYSICAL CHARACTERISTICS		UNIT	CHIP DRAWING
Wafer Size	200	mm	
Die Size (with S/L)	0.308 * 0.233	mm ²	
Scribe line width	60	um	
TOP Metal thickness	3	um	
Top Metallization	Al-Cu		
Wafer Thickness	726	um	
CUP (circuit under PAD) or not	YES		
Bonding Wire Diameter	20	um	

PAD NAME	PAD SIZE (μm ²)	Coordinate
IN 1	60*60	(49,49)
IN 2	60*60	(49,124)
GND	60*60	(124,124)
OUT (Y)	60*60	(199,124)
VDD	60*60	(199,49)

Bonding Diagram Example

