

Quad Operational Amplifiers

General Description

The LM339 series are four independent precision voltage comparators capable of single or split supply operation. These devices are designed to permit a common mode range-to-ground level with single supply operation. Input offset voltage specifications as low as 2.0 mV make this device an excellent selection for many applications in consumer, automotive, and industrial electronics.. The LM339 amplifier is available in micro-sized packaging, such as the standard packages including SOP14, and TSSOP14.

Ordering Information

Part Number	Marking	Package
LM339_S8	LM339 YYWW	SOP14
LM339_TS8	LM339 YYWW	TSSOP14

Features

- Wide Single-Supply Range: 2.0 Vdc to 36 Vdc
- Split-Supply Range: ± 1.0 Vdc to ± 18 Vdc
- Very Low Current Drain Independent of Supply Voltage: 0.4 mA
- Low Input Bias Current: 25 nA
- Low Input Offset Current: 5.0 nA
Low Input Offset Voltage: 5.0 mV (max)
- Input common-mode voltage range includes ground
- Differential input voltage range equal to the power supply voltage
- Output Voltage Compatible with DTL, ECL, TTL, MOS, and CMOS Logic Levels

- SOP14 & TSSOP14 Packages

Applications



- Merchant network and server power supply units
- Multi-function printers
- Power supplies and mobile chargers
- Motor control: AC induction, brushed DC, brushless DC, high-voltage, low-voltage, permanent magnet, and stepper motor
- Desktop PC and motherboard
- Indoor and outdoor air conditioners
- Washers, dryers, and refrigerators
- AC inverters, string inverters, central inverters, and voltage frequency drives
- Uninterruptible power supplies
- Electronic point-of-sale systems

Pin Configuration

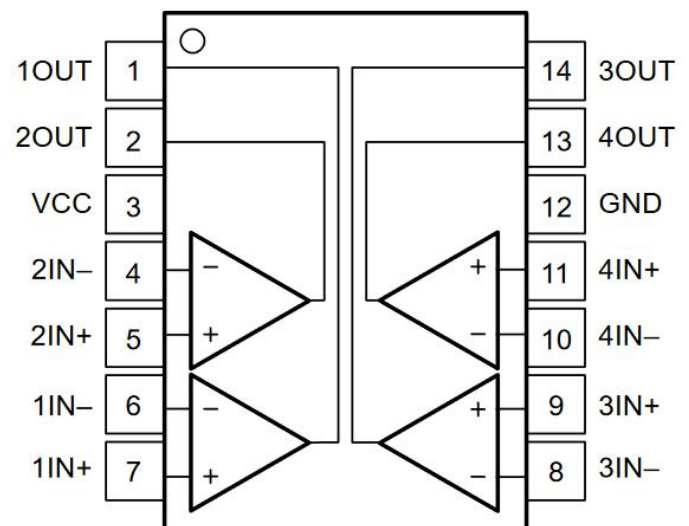

Pin Assignment

Pin Name	SOP8 TSSOP8 Pin No	Pin Function
OUT1	1	Output pin of Comparator 1
OUT2	2	Output pin of Comparator 2
VCC	3	Chip Supply Voltage
IN2-	4	Negative Input of Comparator 2
IN2+	5	Positive Input of Comparator 2
IN1-	6	Negative Input of Comparator 1
IN1+	7	Positive Input of Comparator 1
IN3-	8	Negative Input of Comparator 3
IN3+	9	Positive Input of Comparator 3
IN4-	10	Negative Input of Comparator 4
IN4+	11	Positive Input of Comparator 4
GND	12	Ground
OUT4	13	Output pin of Comparator 4
OUT3	14	Output pin of Comparator 3

Function Block Diagram

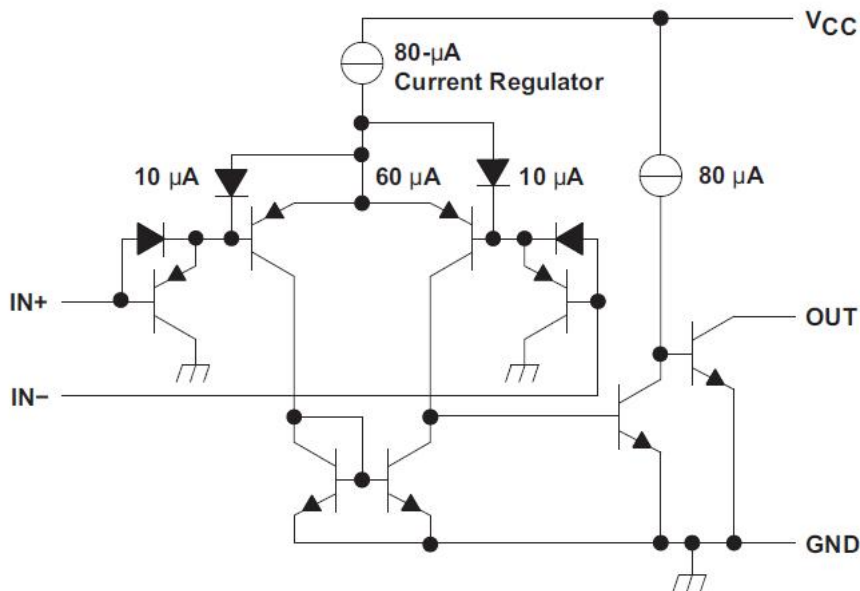

Absolute Maximum Ratings (Note1)

- Supply Voltage $V_{Supply} = V_{CC} - GND$ 40V
- Differential Input Voltage, V_{ID} 40V
- Input Voltage V_{IN1+} , V_{IN1-} , V_{IN2+} , V_{IN2-} , -0.3V to 40V
- Power Dissipation, $PD@T_A=25^\circ C$, SOP-8 0.8W
- Thermal Resistance, θ_{JA} , SOP-8 125°C/W
- Power Dissipation, $PD@T_A=25^\circ C$, TSSOP-8 0.58W
- Thermal Resistance, θ_{JA} , TSSOP-8 172°C/W

- Junction Temperature ----- -40°C to 125°C
- Lead Temperature (Soldering, 10 sec.) ----- 300°C
- Storage Temperature ----- -65°C to 150°C

ESD Rating

- HBM(per ANSI/ESDA/JEDEC JS-001) ----- 2KV
- CDM(per JEDEC specification JESD22-C10) ----- 1KV

Recommended Operating Conditions

- Supply Voltage $V_{Supply} = V_{CC} - GND$ ----- 36V
- Differential Input Voltage, V_{ID} ----- 36V
- Input Voltage $V_{IN1+}, V_{IN1-}, V_{IN2+}, V_{IN2-}$, ----- 36V
- Junction Temperature ----- -40°C to 125°C
- Ambient Temperature ----- -40°C to 85°C

Electrical Characteristics

$V_{CC}=5V, T_A=25^{\circ}C$, unless otherwise specified

Parameter	Symbol	Test Conditions*	Min	Typ	Max	Unit	
Input Offset Voltage	V_{IO}	$V_{CC}=5V$ to 30V, $V_{IC}=V_{ICR}$ min, $V_O=1.4V$	25°C	2	5	mV	
			Full range		9		
Input Offset Current	I_{IO}	$V_O=1.4V$	25°C	5	50	nA	
			Full range		150		
Input Bias Current	I_{IB}	$V_O=1.4V$	25°C	-25	-250	nA	
			Full range		-400		
Common-mode Input Voltage Range**	V_{ICR}		25°C	0 to $V_{CC}-1.5$		V	
			Full range	0 to $V_{CC}-2.0$			
Large-signal Differential Voltage Amplification	A_{VD}	$V_{CC}=15V$, $V_O=1.4V$ to 11.4V, $R_L \geq 15k\Omega$ to V_{CC}	25°C	50	200	V/mV	
High-level Output Current	I_{OH}	$V_{OH}=5V, V_{ID}=1V$, $V_{OH}=30V, V_{ID}=1V$,	25°C	0.1	50	nA	
			Full range		1		μA
Low-level Output Voltage	V_{OL}	$I_{OL}=4mA, V_{ID}=-1V$	25°C	150	400	mV	
			Full range		700		
Low-level Output Current	I_{OL}	$V_{OL}=1.5V, V_{ID}=-1V$	25°C	6		mA	
Supply Current	I_{CC}	$R_L=\infty$	$V_{CC}=5V$	25°C	0.8	1	mA
			$V_{CC}=30V$	Full range		2.5	

Switching Characteristics

$V_{CC}=5V, T_A=25^{\circ}C$, unless otherwise specified

Parameter	Test Conditions		Min	Typ	Max	Unit
Response Time	R_L connected to 5V through 5.1k Ω , $C_L=15pF$ * (Note 1)	100-mV input step with 5-mV overdrive		1.3		μs
		TTL-level input step		0.3		

Typical Characteristics

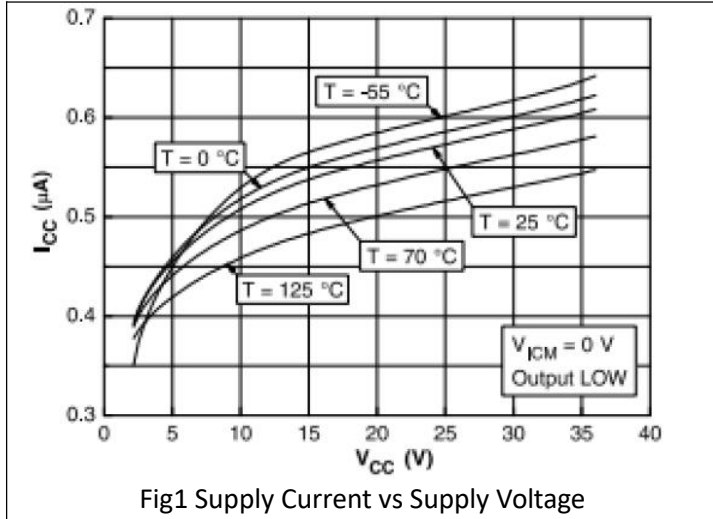

Fig1 Supply Current vs Supply Voltage

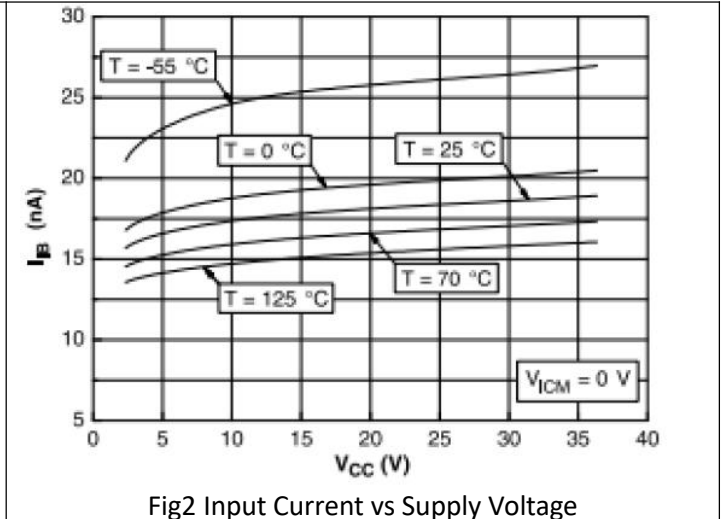

Fig2 Input Current vs Supply Voltage

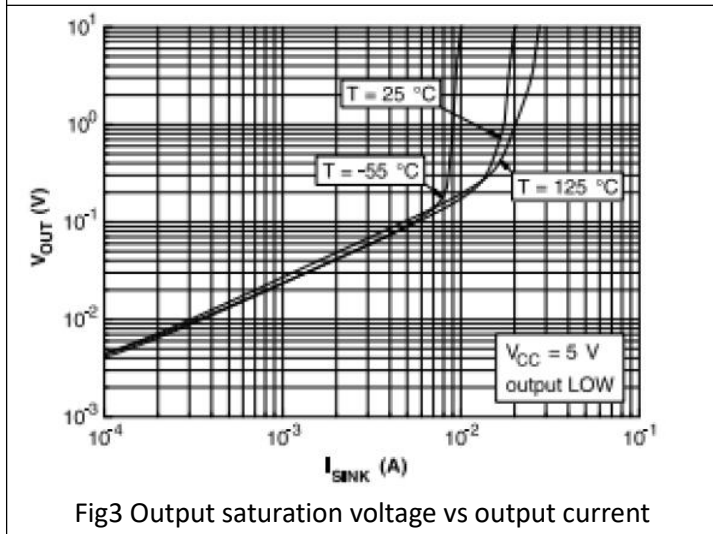

Fig3 Output saturation voltage vs output current

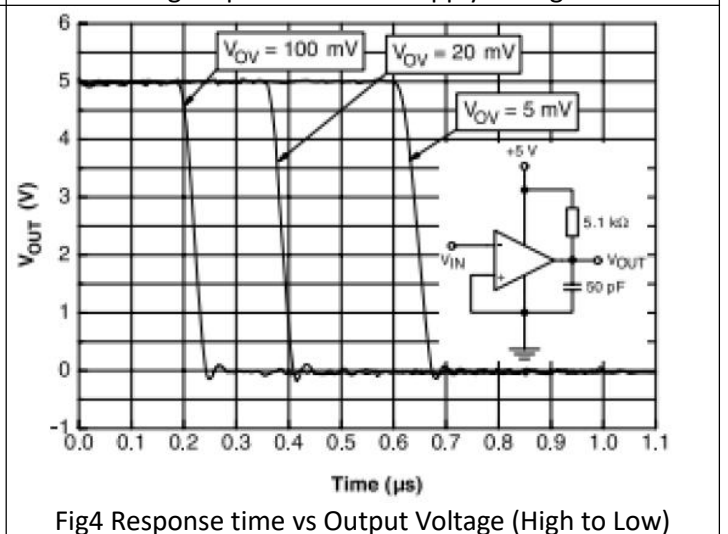

Fig4 Response time vs Output Voltage (High to Low)

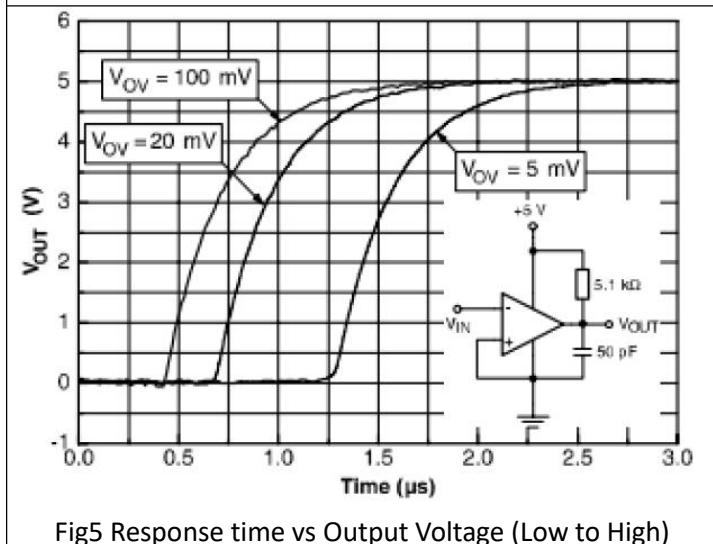

Fig5 Response time vs Output Voltage (Low to High)

IC Operation Information

Overview

These dual comparators have the ability to operate up to absolute maximum of 36 V on the supply pin. This device has proven ubiquity and versatility across a wide range of applications. This is due to very wide supply voltages range, low I_q and fast response of the devices.

The open-drain output allows the user to configure the output's logic high voltage (V_{OH}) and can be used to enable the comparator to be used in AND functionality.

Feature Description

The comparator consists of a PNP darlington pair input, allowing the device to operate with very high gain and fast response with minimal input bias current. The input Darlington pair creates a limit on the input common mode voltage capability, allowing the comparator to accurately function from ground to $V_{CC} - 1.5$ V input. Allow for $V_{CC} - 2$ V at cold temperature.

The output consists of an open drain NPN (pull-down or low side) transistor. The output NPN sinks current when the negative input voltage is higher than the positive input voltage and the offset voltage. The V_{OL} is resistive and scales with the output current.

Voltage Comparison

The device operates solely as a voltage comparator, comparing the differential voltage between the positive and negative pins and outputting a logic low or high impedance (logic high with pullup) based on the input differential polarity.

IC Application Information

The device is typically used to compare a single signal to a reference or two signals against each other. Many users take advantage of the open drain output to drive the comparison logic output to a logic voltage level to an MCU or logic device. The wide supply range and high voltage capability makes this comparator optimal for level shifting to

a higher or lower voltage.

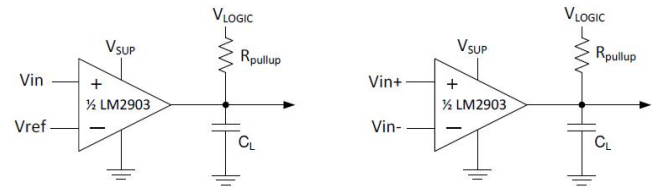

Single-Ended and Differential Comparator Configurations

Input Voltage Range

When choosing the input voltage range, the input common mode voltage range (V_{ICR}) must be taken in to account. If temperature operation is below 25°C the V_{ICR} can range from 0 V to $V_{CC} - 2.0$ V. This limits the input voltage range to as high as $V_{CC} - 2.0$ V and as low as 0 V. Operation outside of this range can yield incorrect comparisons.

The following is a list of input voltage situation and their outcomes:

1. When both $IN-$ and $IN+$ are both within the common-mode range:
 - a. If $IN-$ is higher than $IN+$ and the offset voltage, the output is low and the output transistor is sinking current
 - b. If $IN-$ is lower than $IN+$ and the offset voltage, the output is high impedance and the output transistor is not conducting
2. When $IN-$ is higher than common-mode and $IN+$ is within common-mode, the output is low and the output transistor is sinking current
3. When $IN+$ is higher than common-mode and $IN-$ is within common-mode, the output is high impedance and the output transistor is not conducting
4. When $IN-$ and $IN+$ are both higher than common-mode.

Minimum Overdrive Voltage

Overdrive Voltage is the differential voltage produced between the positive and negative inputs of the comparator over the offset voltage (V_{IO}). To make an accurate comparison the Overdrive Voltage (V_{OD}) should be higher than the input offset voltage (V_{IO}). Overdrive voltage can also determine the response time of the comparator, with the response time decreasing with increasing overdrive. Figures show positive and negative response times with respect to overdrive voltage.

Output and Drive Current

Output current is determined by the load/pull-up resistance and logic/pullup voltage. The output current produces a output low voltage (VOL) from the comparator. In which VOL is proportional to the output current. The output current can also effect the transient response.

Response Time

Response time is a function of input over drive. The rise and falls times can be determined by the load capacitance (C_L), load/pullup resistance (R_{PULLUP}) and equivalent collector-emitter resistance (R_{CE}).

- The rise time (t_R) is approximately $t_R \sim R_{PULLUP} \times C_L$
- The fall time (t_F) is approximately $t_F \sim R_{CE} \times C_L$
- R_{CE} can be determine by taking the slope of its linear region at the desired temperature, or by dividing the V_{OL} by I_{out}

Application Curves

The following curves were generated with 5 V on V_{CC} and V_{Logic} , $R_{PULLUP} = 5.1 \text{ k}\Omega$, and 50 pF scope probe.

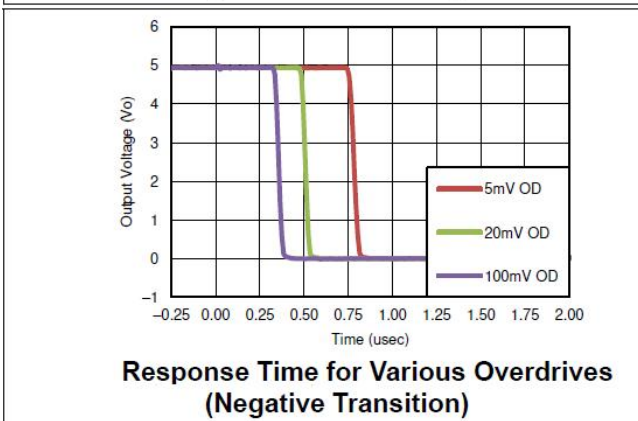
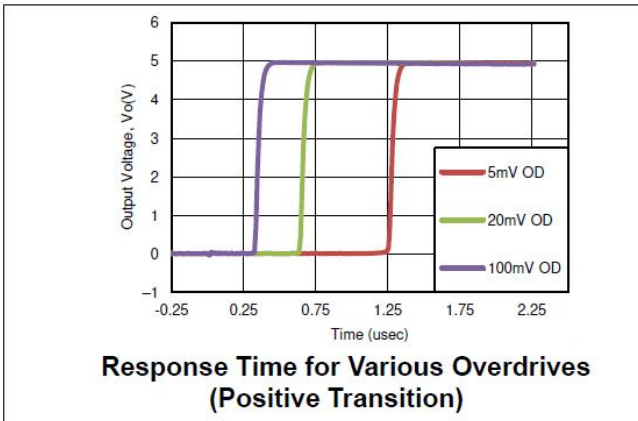

Power Supply Recommendations

For fast response and comparison applications with noisy or AC inputs, we recommends to use a bypass capacitor on the supply pin to reject any variation on the supply voltage. This variation can eat into the input common-mode range of the comparator and create an inaccurate comparison.

Layout Guidelines

For accurate comparator applications without hysteresis it is important maintain a stable power supply with minimized noise and glitches. To achieve this, it is best to add a bypass capacitor between the supply voltage and ground. This should be implemented on the positive power supply and negative supply (if available). If a negative supply is not being used, do not put a capacitor between the IC's GND pin and system ground. Minimize coupling between outputs and inverting inputs to prevent output oscillations. Do not run output and inverting input traces in parallel unless there is a VCC or GND trace between output and inverting input traces to reduce coupling. When series resistance is added to inputs, place resistor close to the device.

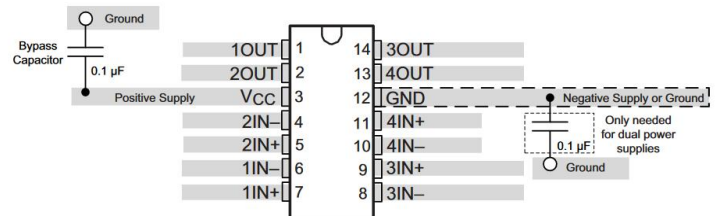

Package Information SOP14

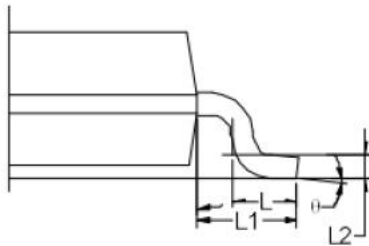
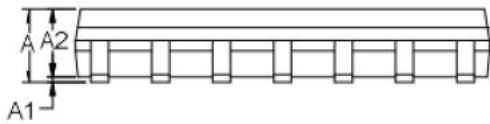
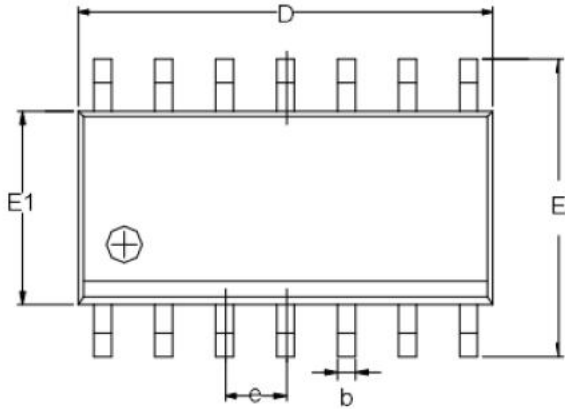

Symbol	Dimensions In Millimeters		
	MIN	TYP	MAX
A	1.35	1.60	1.75
A1	0.10	0.15	0.25
A2	1.25	1.45	1.65
b	0.31		0.51
D	8.45	8.63	8.85
E	5.80	6.00	6.20
E1	3.80	3.90	4.00
e	1.27 BSC		
L	0.40	0.60	0.80
L1	1.05 REF		
L2	0.25 BSC		
θ	0°		8°

Package Information TSSOP14

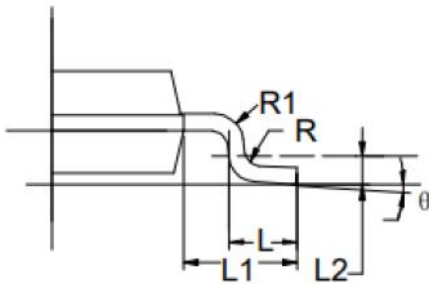
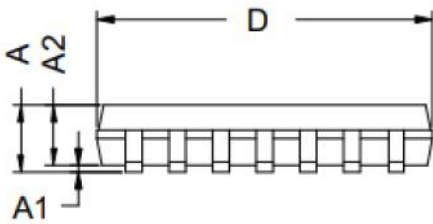
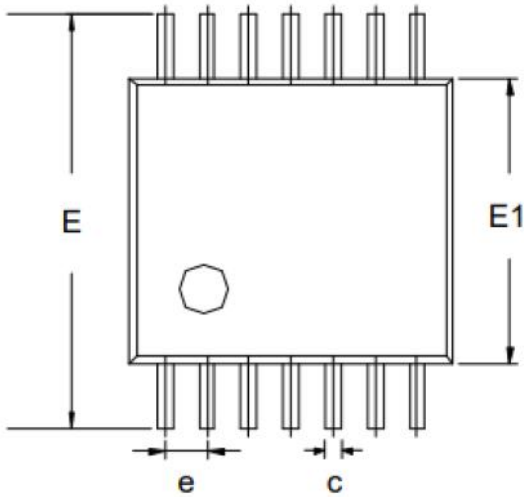

Symbol	Dimensions In Millimeters		
	MIN	TYP	MAX
A	-	-	1.20
A1	0.05	-	0.15
A2	0.80	-	1.05
c	0.19	-	0.30
D	4.86	5.00	5.10
E	6.20	6.40	6.60
E1	4.30	4.40	4.50
e	0.65 BSC		
L	0.45	0.60	0.75
L1	1.00 REF		
L2	0.25 BSC		
R	0.09	-	-
θ	0°	-	8°