

Quadruple Operational Amplifiers

General Description

The LM324 series consists of four independent, high gain, internally frequency compensated operational amplifiers which were designed specifically to operate from a single power supply over a wide range of voltages. Operation from split power supplies is also possible and the low power supply current drain is independent of the magnitude of the power supply voltage.

Application areas include transducer amplifiers, dc gain blocks and all the conventional op amp circuits which now can be more easily implemented in single power supply systems. For example, the LM324 series can be directly operated from the standard +5V power supply voltage which is used in digital systems and will easily provide the required interface electronics without requiring an additional $\pm 15V$ power supply. The LM324 amplifier available in micro-sized packaging, such as the standard packages including SOP8, and TSSOP8.

Ordering Information

Part Number	Marking	Package
LM324_S14	LM324 YYWW	SOP14
LM324_TS14	LM324 YYWW	TSSOP14

Features

- Internally frequency compensated for unity gain
- Large dc voltage gain: 100 dB
- Very low supply current drain (350 μ A/ch)
- Wide bandwidth (unity gain): 700KHz
- Low input offset voltage: 3mV
- Wide power supply range:

Single supply: 3V to 32V

Dual supplies: $\pm 1.5V$ to $\pm 16V$

- Input common-mode voltage range includes ground
- Differential input voltage range equal to the power supply voltage
- SOP8 & TSSOP8 Packages

Applications



- Merchant network and server power supply units
- Multi-function printers
- Power supplies and mobile chargers
- Motor control: AC induction, brushed DC, brushless DC, high-voltage, low-voltage, permanent magnet, and stepper motor
- Desktop PC and motherboard
- Indoor and outdoor air conditioners
- Washers, dryers, and refrigerators
- AC inverters, string inverters, central inverters, and voltage frequency drives
- Uninterruptible power supplies
- Electronic point-of-sale systems

Pin Configuration

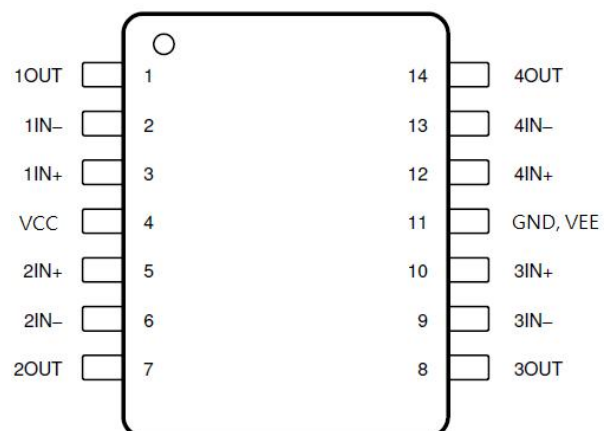

SOP14 & TSSOP14

Pin Assignment

Pin Name	SOP14 TSSOP14 Pin No	Pin Function
OUT1	1	Channel 1 Output
IN1-	2	Channel 1 Inverting Input
IN1+	3	Channel 1 Non-inverting Input
VCC	4	Chip Supply Voltage
IN2+	5	Channel 2 Non-inverting Input
IN2-	6	Channel 2 Inverting Input
OUT2	7	Channel 2 Output
OUT3	8	Channel 3 Output
IN3-	9	Channel 3 Inverting Input
IN3+	10	Channel 3 Non-inverting Input
GND	11	Ground
IN4+	12	Channel 4 Non-inverting Input
IN4-	13	Channel 4 Inverting Input
OUT4	14	Channel 4 Output

Function Block Diagram

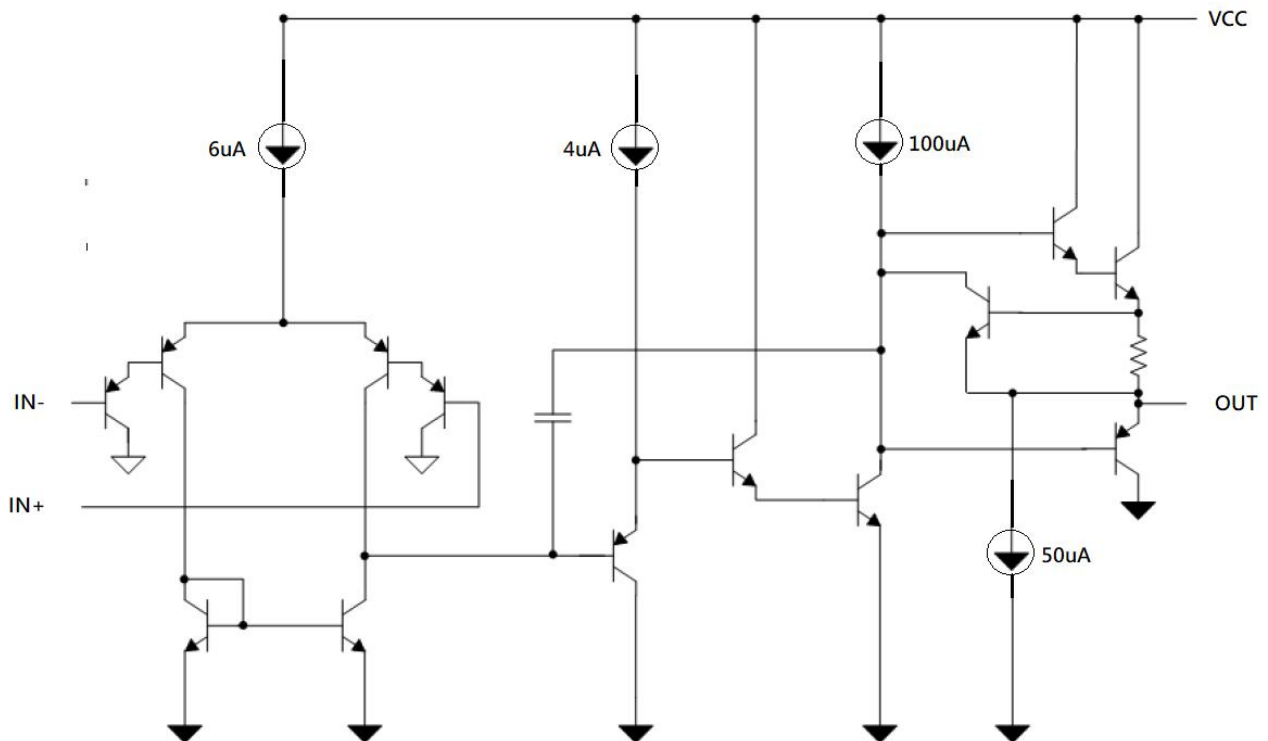

Absolute Maximum Ratings (Note1)

- Supply Voltage $V_{Supply} = V_{CC} - GND$ ----- 36V
- Differential Input Voltage, V_{ID} ----- $\pm 36V$
- Input Voltage $V_{IN1+}, V_{IN1-}, V_{IN2+}, V_{IN2-}$, ----- -0.3V to 36V
- Power Dissipation, $PD@T_A=25^\circ C$, SOP-14-----1.16W

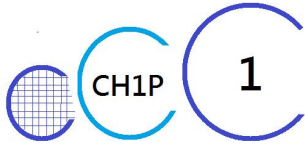

LM324

- Thermal Resistance, θ_{JA} , SOP-14-----86°C/W
- Power Dissipation, PD@ $T_A=25^\circ\text{C}$, TSSOP-14-----0.88W
- Thermal Resistance, θ_{JA} , TSSOP-14-----113°C/W
- Junction Temperature----- -40°C to 125°C
- Lead Temperature (Soldering, 10 sec.)----- 300°C
- Storage Temperature ----- -65°C to 150°C

ESD Rating

- HBM(per ANSI/ESDA/JEDEC JS-001) ----- 2KV
- CDM(per JEDEC specification JESD22-C10) ----- 1KV

Recommended Operating Conditions

- Supply Voltage $V_{\text{Supply}} = V_{CC} - \text{GND}$ ----- 32V
- Differential Input Voltage, V_{ID} ----- $\pm 32\text{V}$
- Input Voltage $V_{IN1+}, V_{IN1-}, V_{IN2+}, V_{IN2-}, V_{IN3+}, V_{IN3-}, V_{IN4+}, V_{IN4-}$, ----- 32V
- Junction Temperature ----- -40°C to 125°C
- Ambient Temperature ----- -40°C to 85°C

Electrical Characteristics

$V_{CC}=5\text{V}, T_A=25^\circ\text{C}$, unless otherwise specified

Parameter	Symbol	Conditions	Min	Typ	Max	Unit	
Input Offset Voltage	V_{IO}	$V_{CC} = 5V \text{ to MAX,}$ $V_{IC} = V_{ICR(min)}$ $V_O = 1.4V$	25°C	3	7	mV	
			Full range		9		
Average Temperature Coefficient of Input Offset Voltage	αV_{IO}		Full range	7		$\mu V/^\circ C$	
Input Offset Current	I_{IO}	$V_O = 1.4V$	25°C	2	50	nA	
			Full range		150		
Average Temperature Coefficient of Input Offset Current	αI_{IO}		Full range	10		$pA/^\circ C$	
Input Bias Current	I_{IB}	$V_O = 1.4V$	25°C	-20	-250	nA	
			Full range		-500		
Common-mode Input Voltage Range	V_{ICR}	$V_{CC} = 5V \text{ to MAX}$	25°C	0 to $V_{CC}-1.5$		V	
			Full range	0 to $V_{CC}-2.0$			
High-level Output Voltage	V_{OH}	$V_{CC} = MAX, R_L = 2k\Omega$	Full range	26		V	
		$V_{CC} = MAX, R_L \geq 10k\Omega$	Full range	27	28		
Low-level Output Voltage	V_{OL}	$R_L \geq 10k\Omega$	Full range	5	20	mV	
Large-signal Differential Voltage Amplification	A_{VD}	$V_{CC} = 15V,$ $V_{OUT} = 1V \text{ to } 11V,$ $R_L \geq 2k\Omega$	25°C	25	100	V/mV	
			Full range	15			
Common-mode Rejection Ratio	CMRR	$V_{CC} = 5V \text{ to MAX,}$ $V_{IC} = V_{ICR(min)}$	25°C	65	80	dB	
Supply Voltage Rejection Ratio ($\Delta V_{CC}/\Delta V_{IO}$)	k_{SVR}	$V_{CC} = 5V \text{ to MAX}$	25°C	65	100	dB	
Crosstalk Attenuation	V_{O1}/V_{O2}	$f = 1 \text{ kHz to } 20 \text{ kHz}$	25°C		120	dB	
Output Current	I_{OUT}	$V_{CC} = 15V,$ $V_{ID} = 1V, V_O = 0$	25°C	-30	-50	mA	
			Full range	-20			
			$V_{CC} = 15V,$ $V_{ID} = -1V, V_O = 15V$	25°C	15	35	mA
				Full range	7		
				25°C	15	28	
$V_{ID} = -1V,$ $V_O = 200mV$	25°C	12	50	μA			
	Full range						
Short-circuit Output Current	I_{OS}	$V_{ID} = -1V, V_O = 15V$	25°C		50	70	mA
Supply Current (two amplifiers)	I_{CC}	$V_O = 2.5V, \text{ No load}$	Full range		0.7	1.2	mA
		$V_{CC} = MAX,$ $V_O = 0.5V_{CC}, \text{ No load}$	Full range		1	2	
Slew Rate	SR	$V_{CC} = 15V,$ $V_{IN} = 0.5 \text{ to } 3V,$ $R_L = 2k\Omega, C_L = 100pF,$ unity gain	25°C		0.7		$V/\mu s$
Gain Bandwidth	GBW	$V_{CC} = 30V,$ $f = 100kHz,$ $V_{IN} = 10mV, R_L = 2k\Omega,$ $C_L = 100pF$	25°C		700		kHz
Total Harmonic Distortion	THD	$f = 1kHz, A_V = 20dB,$ $R_L = 2k\Omega, V_O = 2V_{pp},$ $C_L = 100pF,$	25°C		0.04		%

*All characteristics are measured under the open-loop conditions with zero common-mode input voltage, unless otherwise specified. MAX V_{CC} for testing purposes is 36V, $V_{CC(max)} = 45V$. Full range is $-40^\circ C$ to $+125^\circ C$.

Typical Characteristics

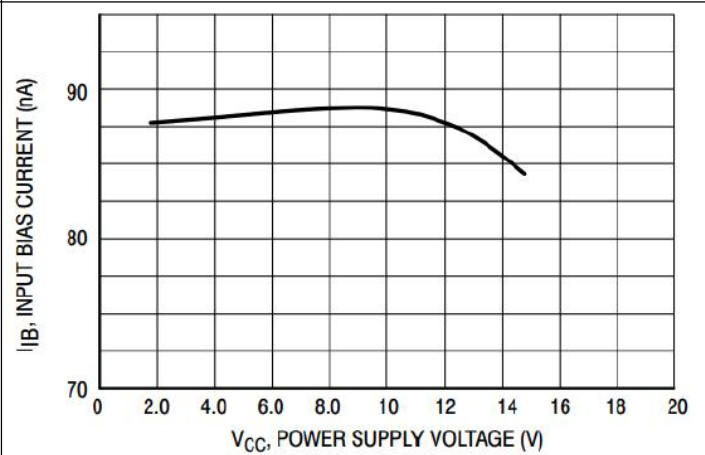
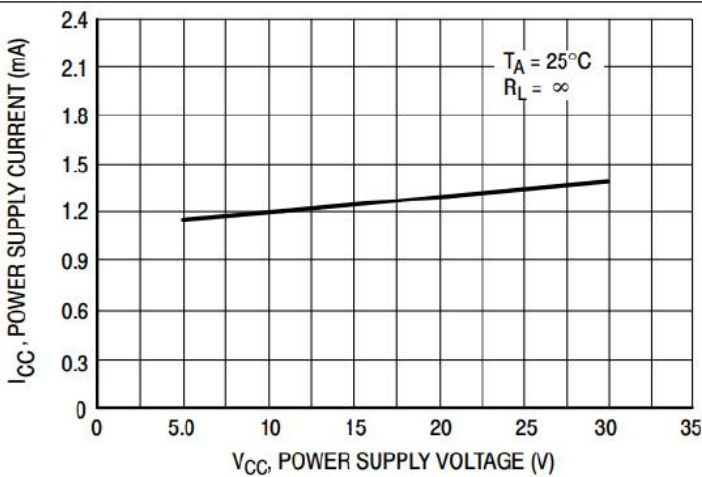
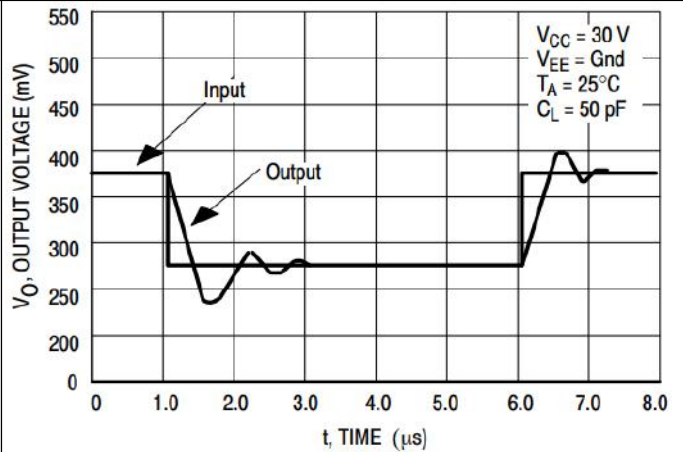
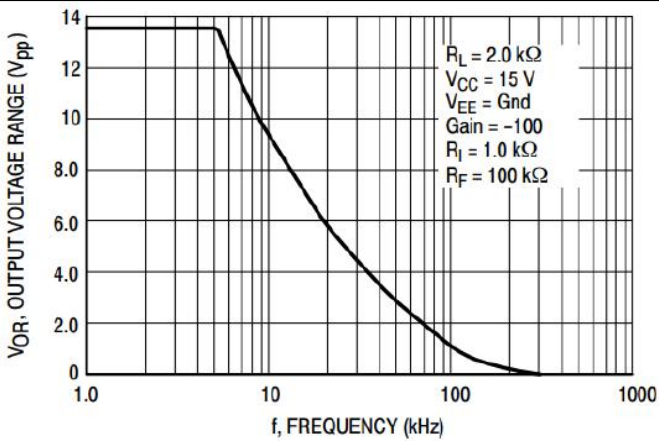
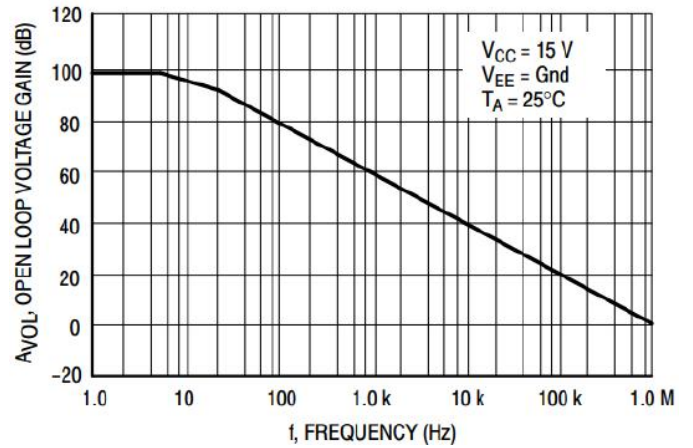
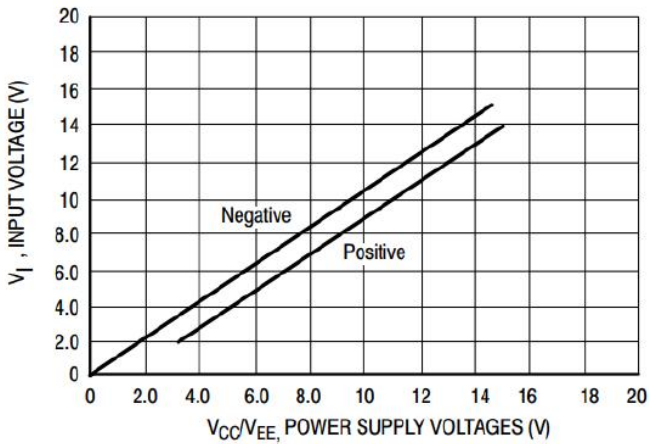

IC Operation Information

Overview

These devices consist of four independent, high-gain frequency-compensated operational amplifiers designed to operate from a single supply over a wide range of voltages. Operation from split supplies also is possible if the difference between the two supplies is within the supply voltage range specified in Recommended Operating Conditions and V_S is at least 1.5 V more positive than the input common-mode voltage. The low supply-current drain is independent of the magnitude of the supply voltage.

Applications include transducer amplifiers, dc amplification blocks, and all the conventional operational amplifier circuits that now can be implemented more easily in single-supply-voltage systems. For example, these devices can be operated directly from the standard 5-V supply used in digital systems and easily can provide the required interface electronics without additional ± 5 -V supplies.

Unity Gain Bandwidth

The unity-gain bandwidth is the frequency up to which an amplifier with a unity gain may be operated without greatly distorting the signal. These devices have a 700KHz unity-gain bandwidth.

Slew Rate

The slew rate is the rate at which an operational amplifier can change its output when there is a change on the input. These devices have a 0.7-V/ μ s slew rate.

Input Common Mode Range

The valid common-mode range is from device ground to $V_S - 1.5$ V ($V_S - 2$ V across temperature). Inputs may exceed V_S up to the maximum V_S without device damage. At least one input must be in the valid input common-mode range for the output to be the correct phase. If both inputs exceed the valid range, then the output phase is undefined. If either input more than 0.3 V below GND then input current should be limited to 1 mA and the output phase is undefined.

Device Functional Modes

These devices are powered on when the supply is connected. This device can be operated as a single-supply operational amplifier or dual-supply amplifier, depending on the application.

IC Application Information

The LM324 operational amplifiers are useful in a wide range of signal conditioning applications. Inputs can be powered before V_S for flexibility in multiple supply circuits. A typical application for an operational amplifier is an inverting amplifier. This amplifier takes a positive voltage on the input, and makes it a negative voltage of the same magnitude. In the same manner, it also makes negative voltages positive.

The supply voltage must be chosen such that it is larger than the input voltage range and output range. For instance, this application scales a signal of ± 0.5 V to ± 1.8 V. Setting the supply at ± 12 V is sufficient to accommodate this application.

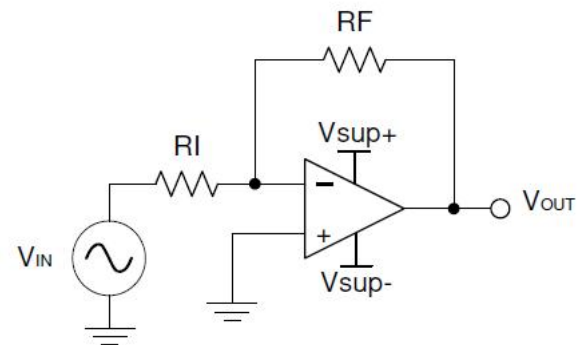

Power Supply Recommendations

Place 0.1- μ F bypass capacitors close to the power-supply pins to reduce errors coupling in from noisy or high-impedance power supplies.

Layout Guidelines

For best operational performance of the device, use good PCB layout practices, including:

- Noise can propagate into analog circuitry through the power pins of the circuit as a whole, as well as the operational amplifier. Bypass capacitors are used to reduce the coupled noise by providing low-impedance power sources local to the analog circuitry.

- Connect low-ESR, 0.1- μF ceramic bypass capacitors between each supply pin and ground, placed as close to the device as possible. A single bypass capacitor from V+ to ground is applicable for single supply applications.

- Separate grounding for analog and digital portions of circuitry is one of the simplest and most-effective methods of noise suppression. One or more layers on multilayer PCBs are usually devoted to ground planes. A ground plane helps distribute heat and reduces EMI noise pickup. Make sure to physically separate digital and analog grounds, paying attention to the flow of the ground current.

- To reduce parasitic coupling, run the input traces as far away from the supply or output traces as possible. If it is not possible to keep them separate, it is much better to cross the sensitive trace perpendicular as opposed to in parallel with the noisy trace.

- Place the external components as close to the device as possible. Keeping RF and RG close to the inverting input minimizes parasitic capacitance, as shown in Layout Examples.

- Keep the length of input traces as short as possible. Always remember that the input traces are the most sensitive part of the circuit.

- Consider a driven, low-impedance guard ring around the critical traces. A guard ring can significantly reduce leakage currents from nearby traces that are at different potentials.

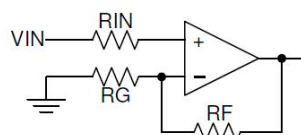
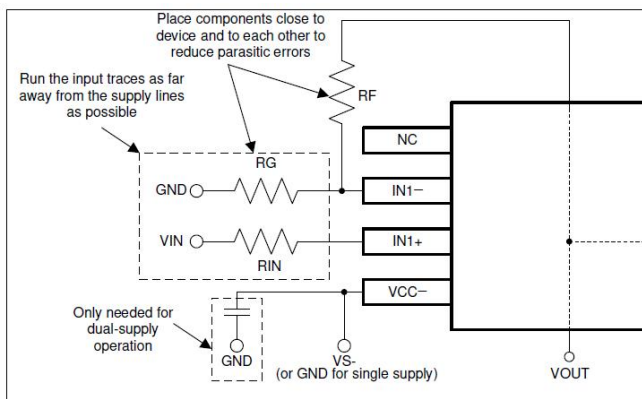

Package Information SOP14

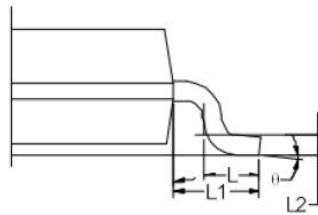
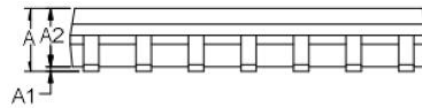
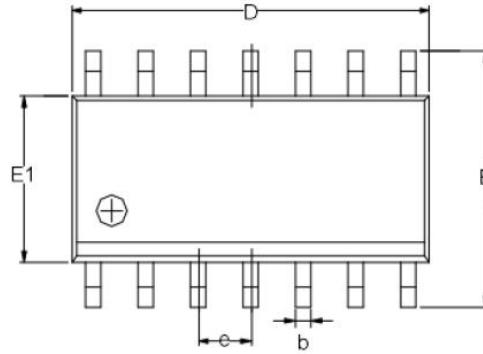

Symbol	Dimensions In Millimeters		
	MIN	TYP	MAX
A	1.35	1.60	1.75
A1	0.10	0.15	0.25
A2	1.25	1.45	1.65
b	0.31		0.51
D	8.45	8.63	8.85
E	5.80	6.00	6.20
E1	3.80	3.90	4.00
e	1.27 BSC		
L	0.40	0.60	0.80
L1	1.05 REF		
L2	0.25 BSC		
θ	0°		8°

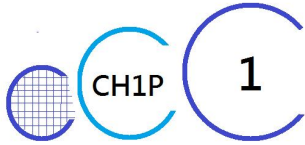

Package Information
TSSOP14

LM324

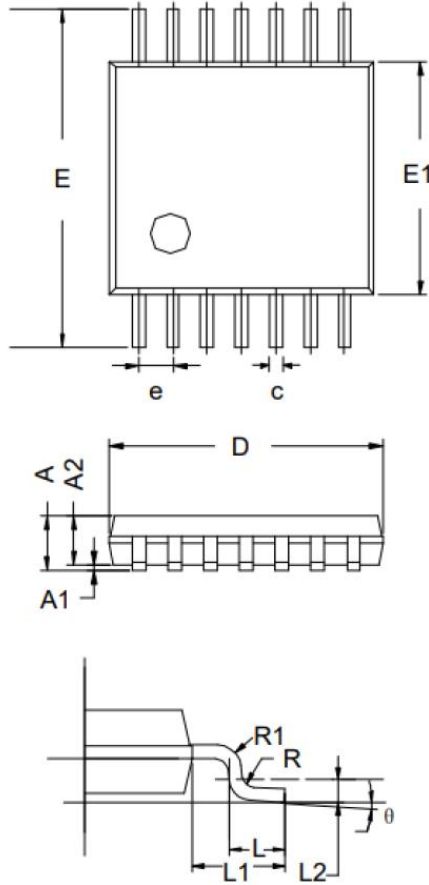

Symbol	Dimensions In Millimeters		
	MIN	TYP	MAX
A	-	-	1.20
A1	0.05	-	0.15
A2	0.80	-	1.05
c	0.19	-	0.30
D	4.86	5.00	5.10
E	6.20	6.40	6.60
E1	4.30	4.40	4.50
e	0.65 BSC		
L	0.45	0.60	0.75
L1	1.00 REF		
L2	0.25 BSC		
R	0.09	-	-
θ	0°	-	8°